

TK-2000

SERVICE MANUAL

REVISED E,T versions

KENWOOD

JVC KENWOOD Corporation

© 2012-8 PRINTED IN JAPAN
B53-7005-10 (Y) PDF

This service manual applies to products with B2802701 or subsequent serial numbers.

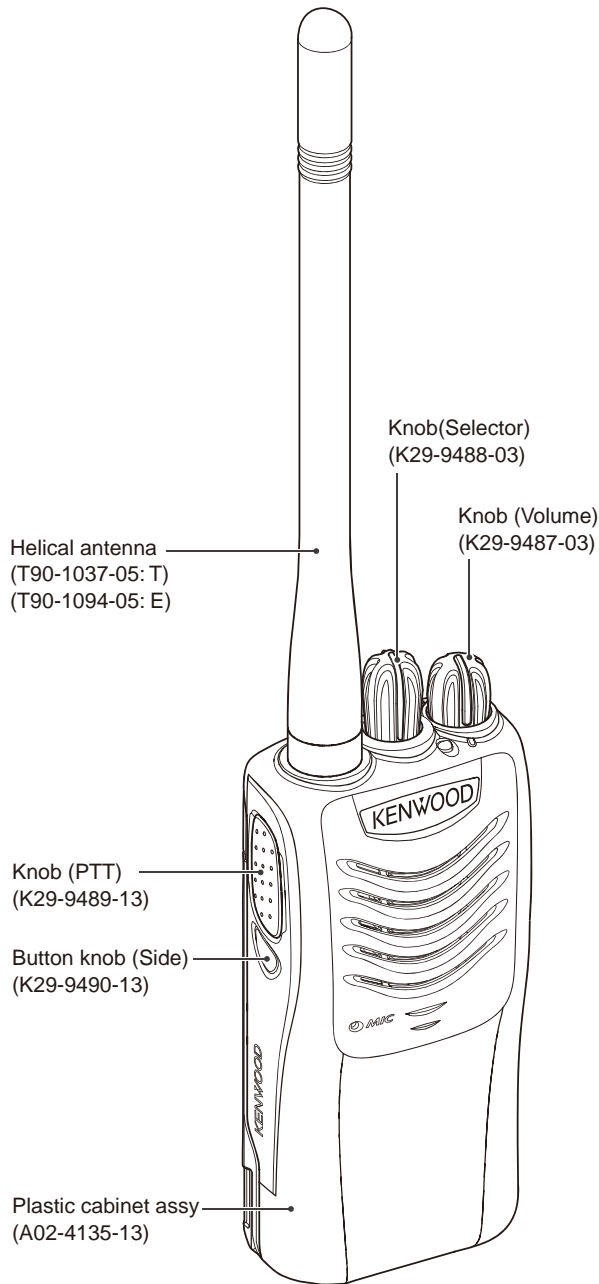

CONTENTS

GENERAL	2
SYSTEM SET-UP	3
REALIGNMENT	3
DISASSEMBLY FOR REPAIR	6
CIRCUIT DESCRIPTION	7
SEMICONDUCTOR DATA	10
COMPONENTS DESCRIPTION	11
PARTS LIST	12
EXPLODED VIEW	17
ADJUSTMENT	18
PC BOARD	
TX-RX UNIT (X57-8092-71)	22
SCHEMATIC DIAGRAM	26
BLOCK DIAGRAM	30
LEVEL DIAGRAM	32
SPECIFICATIONS	33



TK-2000

Document Copyrights

Copyright 2012 by JVC KENWOOD Corporation. All rights reserved.

No part of this manual may be reproduced, translated, distributed, or transmitted in any form or by any means, electronic, mechanical, photocopying, recording, or otherwise, for any purpose without the prior written permission of JVC KENWOOD Corporation.

Disclaimer

While every precaution has been taken in the preparation of this manual, JVC KENWOOD Corporation assumes no responsibility for errors or omissions. Neither is any liability assumed for damages resulting from the use of the information contained herein. JVC KENWOOD Corporation reserves the right to make changes to any products herein at any time for improvement purposes.

Service Manual List

Title	Frequency Range [MHz]	Parts number	market code	Serial number	PCB number
TK-2000	144~174	B53-7005-00	E, T		J79-0362-09
TK-2000	136~174	B53-7005-10 (This service manual)	E, T	From B2802701	J79-0362-29

GENERAL

INTRODUCTION

SCOPE OF THIS MANUAL

This manual is intended for use by experienced technicians familiar with similar types of commercial grade communications equipment. It contains all required service information for the equipment and is current as of the publication date. Changes which may occur after publication are covered by either Service Bulletins or Manual Revisions. These are issued as required.

ORDERING REPLACEMENT PARTS

When ordering replacement parts or equipment information, the full part identification number should be included. This applies to all parts : components, kits, or chassis. If the part number is not known, include the chassis or kit number of which it is a part, and a sufficient description of the required component for proper identification.

PERSONAL SAFETY

The following precautions are recommended for personal safety:

- DO NOT transmit until all RF connectors are verified secure and any open connectors are properly terminated.
- SHUT OFF and DO NOT operate this equipment near electrical blasting caps or in an explosive atmosphere.
- This equipment should be serviced by a qualified technician only.

SERVICE

This transceiver is designed for easy servicing. Refer to the schematic diagrams, printed circuit board views, and alignment procedures contained within.

Model	Type	TX-RX unit	Frequency range	Remarks
TK-2000	E, T	X57-8092-71	136~174MHz	IF1: 38.85MHz LOC: 38.4MHz

SYSTEM SET-UP

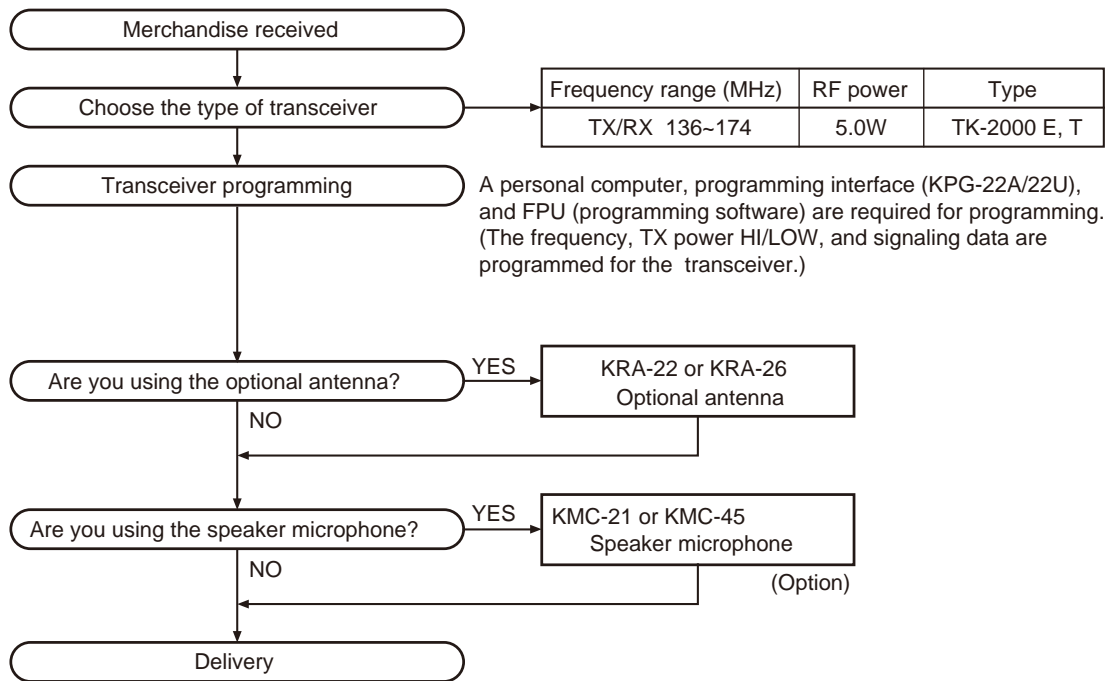

REALIGNMENT

1. Modes

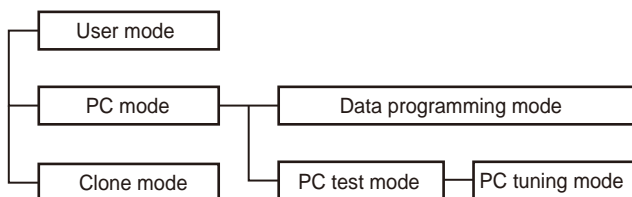

Mode	Function
User mode	For normal use.
PC mode	Used for communication between the transceiver and PC.
Data programming mode	Used to read and write frequency data and other features to and from the transceiver.
PC test mode	Used to check the transceiver using the PC. This feature is included in the FPU.
Clone mode	Used to transfer programming data from one transceiver to another.

2. How to Enter Each Mode

Mode	Operation
User mode	Power ON
PC mode	Received commands from PC
Clone mode	[PTT]+[Side]+Power ON (Two seconds)

3. PC Mode

3-1. Preface

The transceiver is programmed by using a personal computer, a programming interface (KPG-22A/22U) and FPU programming software (KPG-137D : ver.2.30 or later).

The programming software can be used with a PC. Figure 1 shows the setup of a PC for programming.

3-2. Connection Procedure

1. Connect the transceiver to the personal computer with the interface cable.

Note:

- You must install the KPG-22U driver in the computer to use the USB programming interface cable (KPG-22U).

REALIGNMENT

- When the POWER is switched on, user mode can be entered immediately. When the PC sends a command, the transceiver enters PC mode.
When data is read from the transceiver, the red LED lights.
When data is written to by the transceiver, the green LED lights.

Note:

- The data stored in the personal computer must match Model Name and Model Type when it is written into EEPROM.
- Do not press the [PTT] key during data transmission or reception.

3-3. KPG-22A Description

(PC programming interface cable: Option)

The KPG-22A is required to interface the transceiver with the computer. It has a circuit in its D-sub connector (KPG-22A: 9-pin) case that converts the RS-232C logic level to the TTL level.

The KPG-22A connects the SP/MIC connector of the transceiver to the RS-232C serial port of the computer.

3-4. KPG-22U Description

(USB programming interface cable: Option)

The KPG-22U is a cable which connects to a USB port on a computer.

When using the KPG-22U, install the supplied CD-ROM (with driver software) in the computer. The KPG-22U driver runs under Windows XP, Vista or 7.

3-5. Programming Software KPG-137D Description

The KPG-137D (ver.2.30 or later) is the programming software for the transceiver supplied on a CD-ROM. This software runs under windows XP, Vista or 7 on a PC. The software on this disk allows a user to program the transceiver via Programming interface cable (KPG-22A/22U).

Note:

- Use the FPU that matches the market when you first set the market code and model name/frequency data to the service unit. The unit set by mistake cannot be restored.
- Receive frequencies listed below may result in the interference of reception due to the harmonics of internal oscillators. Enter a frequency not listed in the table.

No.	Frequency (MHz)
11	172.79375
12	172.79500
13	172.80000
14	172.80500
15	172.80625

3-6. Programming with PC

If data is transferred to the transceiver from a PC with the FPU, the data for each set can be modified.

Data can be programmed into the EEPROM in RS-232C format via the SP/MIC jack.

In this mode the PTT line operate as TXD and RXD data lines respectively.

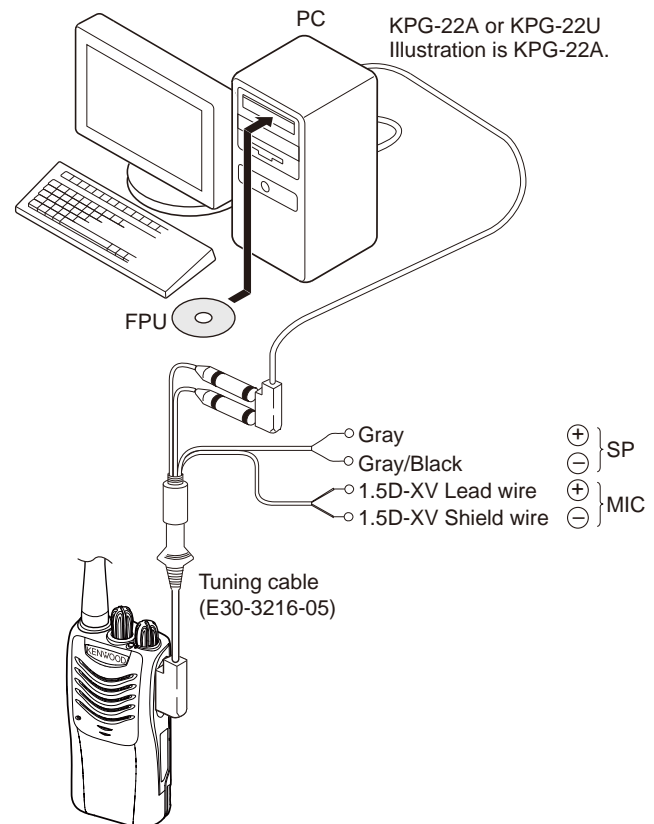

No.	Frequency (MHz)
1	152.69375
2	152.69500
3	152.70000
4	152.70500
5	152.70625
6	153.59375
7	153.59500
8	153.60000
9	153.60500
10	153.60625

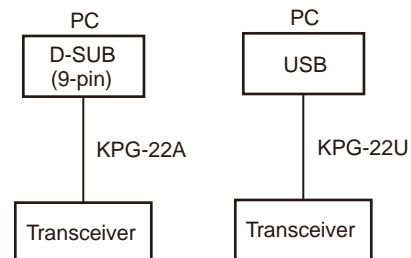

Fig. 1

REALIGNMENT

4. Clone Mode

Programming data can be transferred from one transceiver to another by connecting them via their SP/MIC connectors.

Cloning can be performed as described below (the transmit transceiver is the source and the receive transceiver is the target).

The following data cannot be cloned.

- Tuning data
- Model name data
- ESN data

1. Turn the source transceiver and target transceiver power OFF.
2. Turn the source transceiver power ON while pressing the [PTT] and [Side] keys, to enter clone mode.
3. Connect the cloning cable (part No. E30-3410-05) to the SP/MIC connectors on the source and target transceivers.
4. Turn the target transceiver power ON.
5. Press the [Side] key on the source transceiver. The data of the source is sent to the target. While the source is sending data, red LED will light. While the target is receiving the data, green LED will light. When cloning of data is completed, the source red LED turned off, and the target automatically operates in the User mode.
6. Additional targets can be continuously cloned. When the [Side] key on the source is pressed, the data of the source is sent to the target again. Repeat steps 3 to 5 to clone additional transceivers.

Note:

- The Model name and Market codes must be the same in order to clone the transceiver.
- If the transceivers clone mode is configured as "Disabled", the transceiver cannot enter clone mode.
- If the Read authorization password is set to the transceiver, the transceiver cannot enter to the clone mode.
- Cannot be cloned if the password (overwrite password) is programmed to the target.

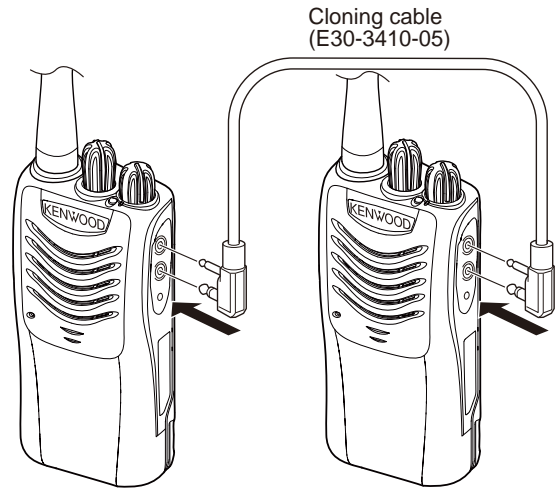
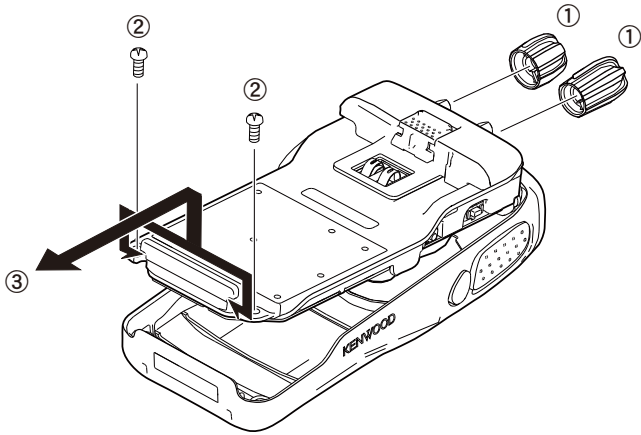

Fig. 2

DISASSEMBLY FOR REPAIR

1. Separating the Case Assembly from the Chassis

1. Remove the two knobs (①).
2. Remove the two screws (②).
3. Expand the right and left sides of the bottom of the case assembly, lift the chassis, and remove it from the case assembly (③).



4. Taking care not to cut the speaker lead (④), open the chassis and case assembly.

Note:

Solder the speaker wire back in its original position if you have removed it.

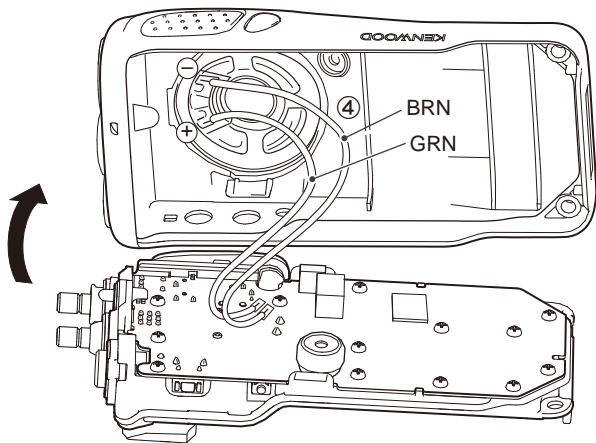

2. Removing the TX-RX unit from the Chassis

1. Remove the packing (⑤).
2. Remove the 13 screws (⑥).
3. Remove the packing (⑦) and two hexagon nuts (⑧).
4. Remove the solder from the antenna terminal using a soldering iron then lift the unit off (⑨).

Note:

When reassembling the unit in the chassis, be sure to solder the antenna terminal.

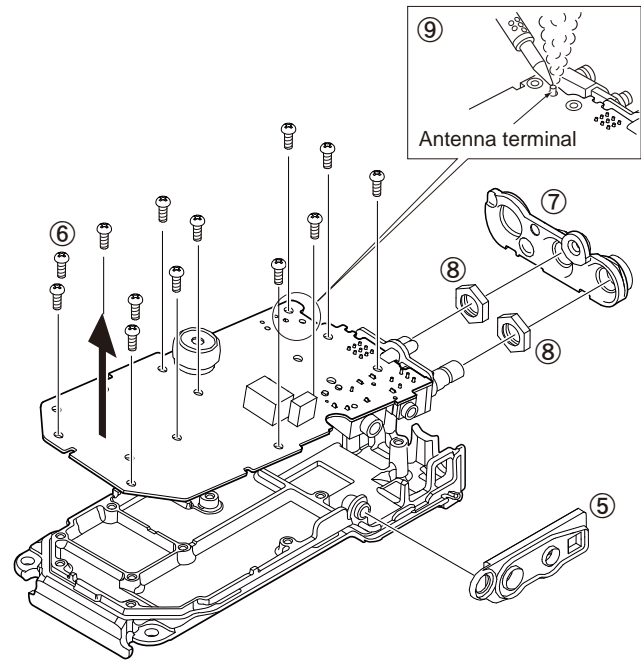

3. Removing the Rear Panel

1. Raise the rear panel on the chassis (⑩).

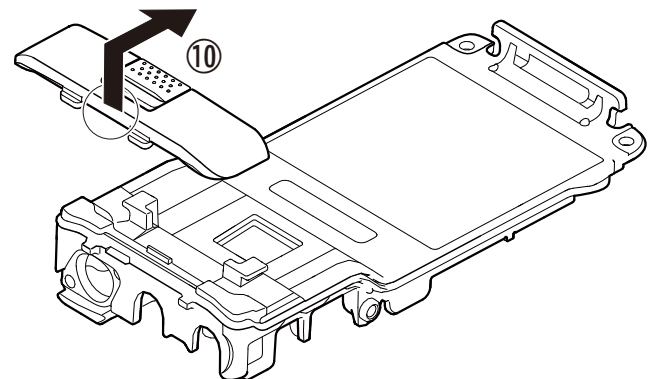

CIRCUIT DESCRIPTION

1. Frequency Configuration

The receiver utilizes double conversion. The first IF is 38.85MHz and the second IF is 450kHz. The first Local oscillator is supplied from the PLL circuit.

The PLL circuit in the transmitter generates the necessary frequencies.

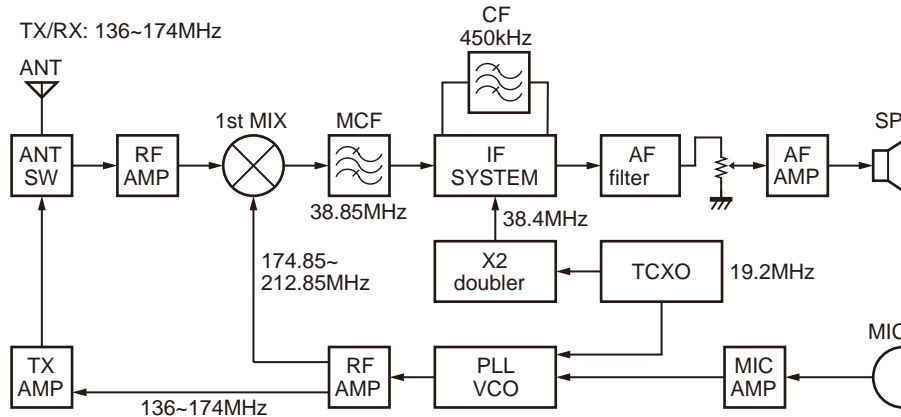

Fig. 1 Frequency configuration

2. Receiver System

The receiver system is shown in Figure 2.

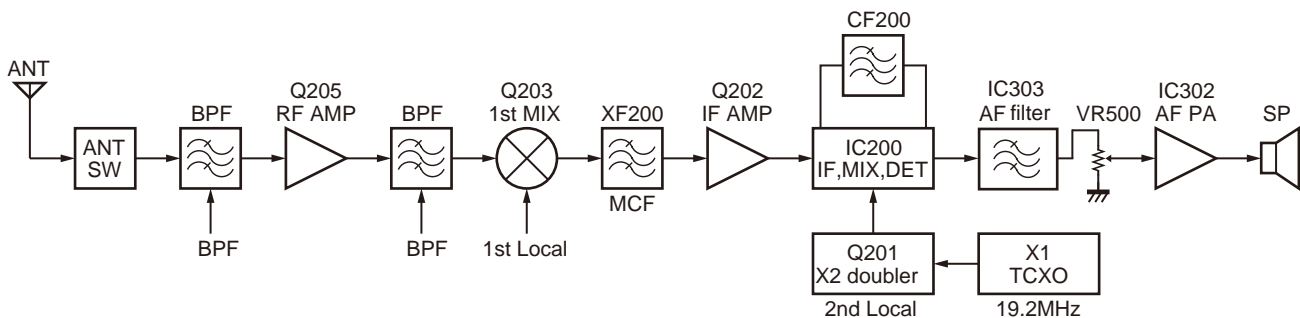

Fig. 2 Receiver system

2-1. RF Amplifier Circuit

The signal coming from the antenna passes through the transmit/receive switching diode circuit (D101, D102, and D103) and a BPF (L210), and is then amplified by the RF amplifier (Q205).

The resulting signal passes through a BPF (L207, L208 and L215) and goes to the mixer. These BPFs are adjusted by variable capacitors (D201, D202 and D204). The input voltage to the variable capacitor is a regulated voltage output from the DAC (IC300).

2-2. First Mixer

The signal from the front end is mixed with the first local oscillator signal generated in the PLL circuit by Q203 to produce a first IF frequency of 38.85 MHz.

The resulting signal passes through the XF200 MCF to cut the adjacent spurious and provide the optimum characteristics, such as adjacent frequency selectivity.

CIRCUIT DESCRIPTION

2-3. IF Amplifier Circuit

The first IF signal is passed through a four-pole monolithic crystal filter (XF200) to remove the adjacent channel signal.

The filtered first IF signal is amplified by the first IF amplifier (Q202) and then applied to the IF system IC (IC200).

The IF system IC provides a second mixer, second local oscillator, limiting amplifier, quadrature detector and RSSI (Received Signal Strength Indicator). The second mixer mixes the first IF signal with the 38.4MHz of the second local oscillator output (TCXO X1) and produces the second IF signal of 450kHz.

The second IF signal is passed through the ceramic filter (CF200) to remove the adjacent channel signal. The filtered second IF signal is amplified by the limiting amplifier and demodulated by the quadrature detector with the ceramic discriminator (CD201). The demodulated signal is routed to the audio circuit.

2-4. Audio Amplifier Circuit

The demodulated signal from IC200 is amplified by IC305, IC303 and goes to AF amplifier through IC302.

The signal then goes through an volume control (VR500), and is routed to an audio power amplifier (IC302) where it is amplified and output to the speaker.

To output sounds from the speaker, IC400 sends a high signal to the SPMUT line and turns IC400 on through Q300, Q301, Q302 and Q306.

3. Transmitter System

3-1. Microphone Amplifier Circuit

The signal from microphone amplified by IC301 and goes through mute switch (IC300).

IC304 is composed of high-pass filter, low-pass filter and pre-emphasis/IDC circuit.

The output signal from the DAC IC (IC300) goes to the VCO modulation input.

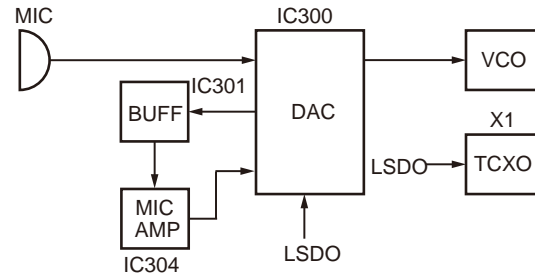

Fig. 3 Microphone amplifier circuit

3-2. Driver and Final Amplifier Circuit

The signal from the T/R switch (D100 is on) is amplified by the pre-drive amplifier (Q100) to 30mW.

The output of the pre-drive amplifier is amplified by the drive amplifier (Q101) and the RF final amplifier (Q102) to 5.0W (1W when the power is low).

The drive amplifier and the RF final amplifier consist of two MOS FET stages.

The output of the RF final amplifier is then passed through the harmonic filter (LPF) and antenna switch (D101 and D102) and is applied to the antenna terminal.

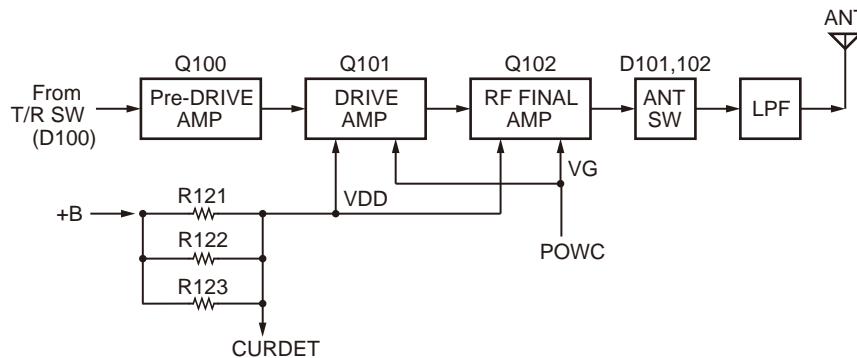

Fig. 4 Drive and final amplifier circuit

CIRCUIT DESCRIPTION

4. Frequency Synthesizer Circuit

4-1. Frequency Synthesizer

The frequency synthesizer consists of the TCXO (X1), VCO, PLL IC (IC1) and buffer amplifiers.

The TCXO generates 19.2MHz. The frequency stability is 5.0 ppm within the temperature range of -30 to $+60^{\circ}\text{C}$.

The frequency tuning and modulation of the TCXO are done to apply a voltage to pin 1 of the TCXO. The output of the TCXO is applied to pin 1 of the PLL IC.

The VCO consists of 1VCO and covers a dual range of the 136.00~174.00MHz and the 174.85~212.85MHz. The VCO generates 174.85~212.85MHz for providing to the first local signal in receive.

The PLL IC consists of a prescaler, reference divider, phase comparator, charge pump (The frequency step of the PLL circuit is 5 or 6.25 kHz).

PLL data is output from DATA (pin 19), CLOCK (pin 18) and PLDL (pin 20) of the MCU (IC400). The data are input to the PLL IC when the channel is changed or when transmission is changed to reception and vice versa. A PLL lock condition is always monitored by the pin 22 (PLUL) of the MCU. When the PLL is unlocked, the PLUL goes low.

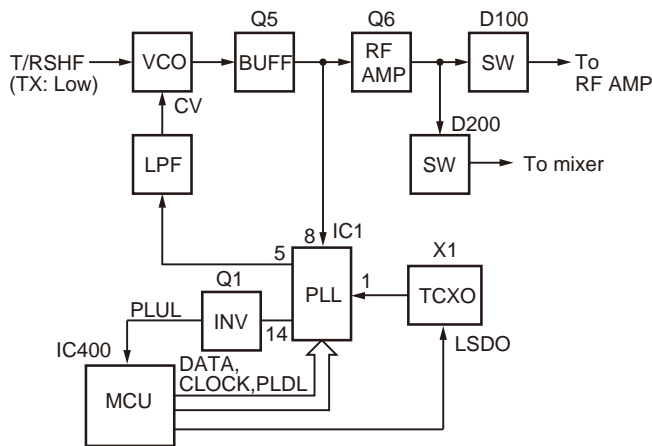

Fig. 5 PLL block diagram

5. Control Circuit

The control consists of the MCU (IC400) and its peripheral circuits. It controls the TX-RX unit. IC400 mainly performs the following;

- 1) Switching between transmission and reception by PTT signal input.
- 2) Reading channel information, frequency, and program data from the memory circuit.
- 3) Sending frequency program data to the PLL.
- 4) Controlling squelch on/off via the DC voltage from the squelch circuit.
- 5) Controlling the audio mute circuit via the decode data input.
- 6) Transmitting tone and encode data.

Note:

The EEPROM stores tuning data (Deviation, Squelch, etc.).

Realign the transceiver after replacing the EEPROM.

6. Signaling Circuit

6-1. Encode

■ Low-speed data (QT, DQT)

Low-speed data is output from pin 49 (LSDO) of the MCU (IC400). The signal passes through a low-pass CR filter. The signal is mixed with the audio signal and goes to the VCO and TCXO (X1) modulation input after signal processing in the DAC IC (IC300).

■ High-speed data (DTMF)

High-speed data (HSD) is output from pin 50 (HSDO) of the MCU.

The signal passes through a low-pass CR filter. TX deviation making an adjustment by MCU is applied to the DAC IC (IC300). The signal is mixed with the audio signal and goes to the VCO and TCXO.

6-2. Decode

■ QT/DQT

The output signal from IF IC (IC200) enters the MCU (IC400) through IC300. IC400 determines whether the QT or DQT matches the preset value, and controls the SPMUT and the speaker output sounds according to the squelch results.

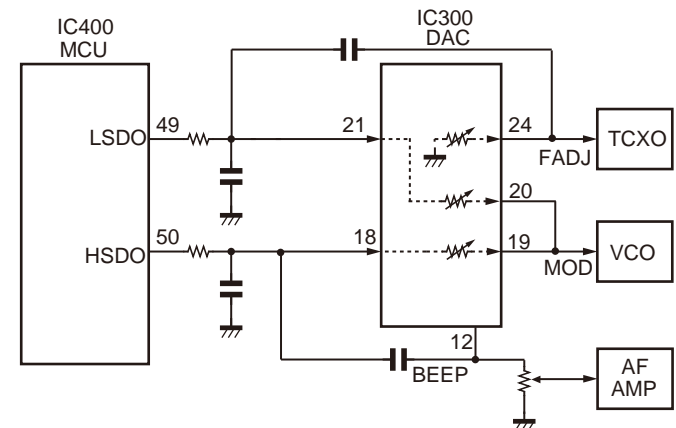

Fig. 6 Encode

7. Power Supply

There are five 5V power supplies for the MCU:

5M is always output while the power is on.

5C is a common 5V and is output when SAVE is not set to ON.

5R is 5V for reception and output during reception.

5T is 5V for transmission and output during transmission.

5MS is 5V for the SP/MIC connector and the DAC IC (IC300).

SEMICONDUCTOR DATA

MCU: F2136ACNKDRB (TX-RX unit IC400)

Pin No.	Signal Name	I/O	Function
1	NC	O	NC
2	VREF	-	Reference voltage input
3	MODE	I	Mode select for MCU
4	NC	O	NC
5	NC	O	NC
6	RESET	I	Reset signal input
7	XOUT	O	Oscillation circuit
8	Vss	-	GND
9	XIN	I	Oscillation circuit
10	Vcc	-	Power supply
11	BSFT	O	Beat shift for MCU clock
12	NC	O	NC
13	NC	O	NC
14	NC	O	NC
15	E2WP	O	Write protect for EEPROM
16	E2DAT	I/O	Data input/output from EEPROM
17	E2CLK	O	Clock for EEPROM
18	CLOCK	O	Clock for PLL/DAC IC
19	DATA	O	Data for PLL/DAC IC
20	PLDL	O	Load enable for PLL IC
21	PLPS	O	Power saving for PLL IC
22	PLUL	I	Lock detect signal from PLL IC
23	NC	O	NC
24	EN4	I	Encoder input 4
25	EN3	I	Encoder input 3
26	EN2	I	Encoder input 2
27	EN1	I	Encoder input 1
28	NC	O	NC
29	OPTDET	I	2pin option detection
30	LEDR	O	LED (red) control
31	LEDG	O	LED (green) control
32	SPMUT	O	Power switch for AF amp
33	NC	O	NC
34	5TC	O	5T control
35	5CC	O	5C control (SAVE)
36	5MSC	O	5MS control
37	DACLD	O	Load enable for DAC IC
38	PTT	I	PTT key input
39	PFKEY	I	PF key input
40	INT	I	INT signal input
41	VDCSW	O	Voltage discharge switch
42	WID/NAR	O	Wide/Narrow control
43	RXD	I	Serial data input (FPU)
44	TXD	O	Serial data output (FPU)

Pin No.	Signal Name	I/O	Function
45	NC	O	NC
46	NC	O	NC
47	VOXIN	I	VOX level input
48	CVDET	I	VCO voltage detection
49	LSDO	O	Low speed data output
50	HSDO	O	DTMF/beep output
51	BATT	I	Battery voltage input
52	RSSI	I	RSSI input
53	SQL	I	Squelch input
54	LSDIN	I	LSD input
55	THDET	I	Thermistor input
56	CURDET	I	Current detection
57	T/RSHF	O	VCO shift control
58	5VC	O	5V control
59	NC	O	NC
60	NC	O	NC
61	NC	O	NC
62	TYPE2	I	Destination selection 2
63	TYPE1	I	Destination selection 1
64	5RC	O	5R control

COMPONENTS DESCRIPTION

TX-RX unit (X57-8092-71)

Ref. No.	Part Name	Description
IC1	IC	PLL system
IC200	IC	FM IF system
IC300	IC	DAC
IC301	IC	LSD buffer
IC302	IC	AF power AMP
IC303	IC	AF filter
IC304	IC	MIC AMP
IC305	IC	QT/DQT filter
IC400	IC	MCU
IC401	IC	EEPROM
IC500	IC	Voltage detector/RESET
IC501	IC	Voltage regulator/5V
IC503	IC	Voltage regulator/5V
Q1	Transistor	DC switch
Q2	Transistor	TX/RX RF switch
Q3	Transistor	Ripple filter
Q4	FET	VCO
Q5	Transistor	RF buffer AMP
Q6	Transistor	RF AMP
Q7	Transistor	Voltage regulator/3V
Q100	Transistor	Pre drive AMP
Q101	FET	Drive AMP
Q102	FET	Final AMP
Q103	Transistor	Voltage discharge switch
Q200	Transistor	W/N switch
Q201	Transistor	Doubler
Q202	Transistor	IF AMP
Q203	FET	Mixer
Q205	FET	RF AMP
Q300	Transistor	DC switch
Q301	Transistor	DC switch
Q302	FET	Mute switch
Q303	FET	DC switch
Q304	Transistor	DC switch
Q305	Transistor	W/N switch
Q306	FET	Mute switch
Q400	Transistor	Switch
Q401	Transistor	DC switch
Q402	Transistor	DC switch
Q403	Transistor	DC switch
Q500	FET	DC switch
Q501	FET	DC switch
Q502	Transistor	DC switch
D1	Diode	Current steering

Ref. No.	Part Name	Description
D2	Variable capacitance diode	Frequency control/ VCO
D3	Variable capacitance diode	Frequency control/ VCO
D4	Diode	TX/RX RF switch
D5	Variable capacitance diode	Modulator /TX VCO
D6	Variable capacitance diode	Frequency control/ VCO
D7	Diode	Ripple filter
D100	Diode	TX/RX RF switch
D101	Diode	ANT switch
D102	Diode	ANT switch
D103	Diode	ANT switch
D200	Diode	TX/RX RF switch
D201	Variable capacitance diode	RX BPF tuning
D202	Variable capacitance diode	RX BPF tuning
D203	Variable capacitance diode	RX BPF tuning
D204	Variable capacitance diode	RX BPF tuning
D301	Diode	Current steering
D400	LED	LED/green
D401	LED	LED/red
D402	Diode	VCO speed up
D500	Diode	Protect
D501	Diode	Current steering

TK-2000

PARTS LIST

* New Parts. Δ indicates safety critical components.

Parts without **Parts No.** are not supplied.

Les articles non mentionnés dans le **Parts No.** ne sont pas fournis.

Teile ohne **Parts No.** werden nicht geliefert.

L : Scandinavia

Y : PX (Far East, Hawaii)

C : China

K : USA

T : England

X : Australia

P : Canada

E : Europe

M : Other Areas

TK-2000

TX-RX UNIT (X57-8092-71)

Ref. No.	Address	New parts	Parts No.	Description	Desti-nation
TK-2000					
1	1A,2A		A02-4135-13	PLASTIC CABINET ASSY	
2	3A		A10-4150-41	CHASSIS	
3	3B		A82-0081-02	REAR PANEL	
4	2B		B11-1892-03	ILLUMINATION GUIDE	
6	3B		E04-0486-05	RF COAXIAL RECEPTACLE(SMA)	
7	2A		E23-1364-04	TERMINAL	
8	1B		E37-1539-05	PROCESSED LEAD WIRE(SP-BRN)	
9	1B		E37-1540-05	PROCESSED LEAD WIRE(SP+GRN)	
10	2A		E72-0436-03	TERMINAL BLOCK	
11	2B		F10-3186-04	SHIELDING CASE(CF200)	
12	3B		G01-4571-04	COIL SPRING	
13	2A		G11-4437-04	SHEET(Q102-CHASSIS)	
14	3A		G13-2364-14	CUSHION(CHASSIS)	
15	3B		G13-2366-04	CUSHION(BATT-TERMINAL)	
16	2A		G53-1867-13	PACKING(CHASSIS)	
18	1B		G53-1868-12	PACKING(TOP)	
19	3B		G53-1869-13	PACKING(JACK)	
20	1A		G53-1871-14	PACKING(MIC)	
22	1B		K29-9487-03	KNOB(VOL)	
23	1B		K29-9488-03	KNOB(SELECTOR)	
24	1A		K29-9489-13	KNOB(PTT)	
25	1A		K29-9490-13	BUTTON KNOB(SIDE)	
26	2B		K29-9491-03	LEVER KNOB(BATTERY)	
A	2B		N09-2438-05	BINDING HEAD SCREW(ANT SMA)	
B	3A		N30-2606-48	PAN HEAD MACHINE SCREW(CABINET)	
C	1A,2A		N83-2005-48	PAN HEAD TAPTITE SCREW(X57)	
28	1B		T07-0787-05	SPEAKER	
				ACCESSORY	
			B09-0744-03	CAP ACCESSORY	
			B62-2418-00	INSTRUCTION MANUAL ACCESSORY	
			B62-2425-00	INSTRUCTION MANUAL ACCESSORY	
			B62-2426-00	INSTRUCTION MANUAL ACCESSORY	
			B62-2427-00	INSTRUCTION MANUAL ACCESSORY	
			B62-2428-00	INSTRUCTION MANUAL ACCESSORY	
			B62-2429-00	INSTRUCTION MANUAL ACCESSORY	
			B62-2430-00	INSTRUCTION MANUAL ACCESSORY	
			B62-2431-00	INSTRUCTION MANUAL ACCESSORY	
			J29-0756-05	BELT CLIP ACCESSORY	
			N35-3005-43	BINDING HEAD SCREW ACCESSORY	
			T90-1037-05	HELICAL ANTENNA ACCESSORY	T
			T90-1094-05	HELICAL ANTENNA ACCESSORY	E
		*	W08-1246-25	AC ADAPTER ACCESSORY	E
			W08-1249-35	CHARGER ACCESSORY	
		*	W08-1251-25	AC ADAPTER ACCESSORY	T
			W09-1073-25	BATTERY ASSY ACCESSORY	
			X57-8092-72	TX-RX UNIT(FOR SERVICE)	

Ref. No.	Address	New parts	Parts No.	Description	Desti-nation
TX-RX UNIT (X57-8092-71)					
D400			B30-1782-05	LED(GREEN)	
D401			B30-1779-05	LED(RED)	
C1			CK73GB1E154K	CHIP C 0.15UF	K
C2			CK73HB1A184K	CHIP C 0.18UF	K
C4			CS77MA1A6R8M	CHIP TNTL 6.8UF	10WV
C5		*	CS77MA1ER68M	CHIP TNTL 0.68UF	25WV
C6			CK73HB1A105K	CHIP C 1.0UF	K
C7			CC73HCH1H560G	CHIP C 56PF	G
C8 ,9			CK73HB1A104K	CHIP C 0.10UF	K
C11			CK73HB1A105K	CHIP C 1.0UF	K
C12			CC73HCH1H0R5B	CHIP C 0.5PF	B
C13			CS77MP1C010M	CHIP TNTL 1.0UF	16WV
C14 ,15			CK73HB1C103K	CHIP C 0.010UF	K
C16			CK73HB1H102K	CHIP C 1000PF	K
C17			CC73HCH1H090B	CHIP C 9.0PF	B
C18 ,19			CK73HB1H102K	CHIP C 1000PF	K
C20			CS77MA1C100M	CHIP TNTL 10UF	16WV
C21			CC73GCH1H090B	CHIP C 9.0PF	B
C22			CC73GCH1H120G	CHIP C 12PF	G
C23 ,24			CK73HB1H102K	CHIP C 1000PF	K
C25			CK73HB1C103K	CHIP C 0.010UF	K
C26			CK73HB1H102K	CHIP C 1000PF	K
C27			CC73HCH1H220J	CHIP C 22PF	J
C28			CK73HB1H102K	CHIP C 1000PF	K
C29			CC73GCH1H0R5B	CHIP C 0.5PF	B
C30			CK73HB1H102K	CHIP C 1000PF	K
C31			CK73HB1C103K	CHIP C 0.010UF	K
C32			CK73HB1H102K	CHIP C 1000PF	K
C33			CC73HCH1H470J	CHIP C 47PF	J
C34			CK73HB1H102K	CHIP C 1000PF	K
C35			CC73HCH1H150J	CHIP C 15PF	J
C36			CC73HCH1H120G	CHIP C 12PF	G
C37			CC73HCH1H150J	CHIP C 15PF	J
C38			CC73GCH1H220J	CHIP C 22PF	J
C39			CC73HCH1H120J	CHIP C 12PF	J
C40 ,41			CK73HB1H102K	CHIP C 1000PF	K
C42			CC73HCH1H150J	CHIP C 15PF	J
C43			CK73HB1H102K	CHIP C 1000PF	K
C44			CK73HB1A104K	CHIP C 0.10UF	K
C57			CC73HCH1H471J	CHIP C 470PF	J
C59			CK73HB1C333K	CHIP C 0.033UF	K
C100			CC73HCH1H220J	CHIP C 22PF	J
C101-104			CK73HB1H102K	CHIP C 1000PF	K
C105			CK73HB1A105K	CHIP C 1.0UF	K
C106			CC73HCH1H090B	CHIP C 9.0PF	B
C107,108			CK73HB1H102K	CHIP C 1000PF	K
C109			CC73HCH1H220J	CHIP C 22PF	J
C110			CK73HB1H102K	CHIP C 1000PF	K
C111			CK73HB1C103K	CHIP C 0.010UF	K
C112			CC73HCH1H560J	CHIP C 56PF	J
C113,114			CK73HB1H102K	CHIP C 1000PF	K
C116			CK73HB1C103K	CHIP C 0.010UF	K
C117			CK73FB1A225K	CHIP C 2.2UF	K

PARTS LIST

TX-RX UNIT (X57-8092-71)

Ref. No.	Address	New parts	Parts No.	Description	Destination	Ref. No.	Address	New parts	Parts No.	Description	Destination
C119,120			CK73HB1H102K	CHIP C 1000PF K		C240			CC73HCH1H010B	CHIP C 1.0PF B	
C121			CC73GCH1H390J	CHIP C 39PF J		C242			CC73HCH1H390J	CHIP C 39PF J	
C122			CC73GCH1H470J	CHIP C 47PF J		C243			CC73HCH1H1R5B	CHIP C 1.5PF B	
C123			CC73GCH1H100C	CHIP C 10PF C		C244-246			CK73HB1H102K	CHIP C 1000PF K	
C124			CK73HB1H102K	CHIP C 1000PF K		C247			CC73HCH1H470J	CHIP C 47PF J	
C125			CC73GCH1H270J	CHIP C 27PF J		C248			CK73HB1H102K	CHIP C 1000PF K	
C126			CC73GCH1H050B	CHIP C 5.0PF B		C249			CC73HCH1H390J	CHIP C 39PF J	
C127			CK73GB1H102K	CHIP C 1000PF K		C250			CC73HCH1H470G	CHIP C 47PF G	
C128			CC73GCH1H060B	CHIP C 6.0PF B		C251			CK73HB1H102K	CHIP C 1000PF K	
C129			CK73HB1H102K	CHIP C 1000PF K		C253			CC73HCH1H0R5B	CHIP C 0.5PF B	
C130			CC73GCH1H220J	CHIP C 22PF J		C254			CC73HCH1H390J	CHIP C 39PF J	
C131			CK73GB1H102K	CHIP C 1000PF K		C256			CK73HB1H102K	CHIP C 1000PF K	
C132			CC73GCH1H120J	CHIP C 12PF J		C262			CK73HB1H102K	CHIP C 1000PF K	
C134			CK73HB1H102K	CHIP C 1000PF K		C266			CC73HCH1H2R5B	CHIP C 2.5PF B	
C135			CC73GCH1H060B	CHIP C 6.0PF B		C272			CK73HB1C103K	CHIP C 0.010UF K	
C136			CC73GCH1H270J	CHIP C 27PF J		C300,301			CK73HB1H102K	CHIP C 1000PF K	
C137			CC73GCH1H060B	CHIP C 6.0PF B		C302			C92-0953-05	ELECTRO 100UF 6.3WV	
C138			CC73GCH1H120J	CHIP C 12PF J		C303			CK73HB1C473K	CHIP C 0.047UF K	
C139			CK73FB1A225K	CHIP C 2.2UF K		C304			CK73FB1A106K	CHIP C 10UF K	
C145			CK73HB1H102K	CHIP C 1000PF K		C305			CK73HB1C103K	CHIP C 0.010UF K	
C146			CC73HCH1H180J	CHIP C 18PF J		C306			CK73HB1A224K	CHIP C 0.22UF K	
C152			CK73HB1A104K	CHIP C 0.10UF K		C308			CK73GB1E105K	CHIP C 1.0UF K	
C158,159			CK73HB1H102K	CHIP C 1000PF K		C309			CK73HB1A104K	CHIP C 0.10UF K	
C200			CK73FB1A106K	CHIP C 10UF K		C310			CK73HB1C473K	CHIP C 0.047UF K	
C201			CK73HB1H102K	CHIP C 1000PF K		C311			CK73HB1A105K	CHIP C 1.0UF K	
C202			CK73HB1C103K	CHIP C 0.010UF K		C312			CK73HB1C473K	CHIP C 0.047UF K	
C203			CC73HCH1H331J	CHIP C 330PF J		C313			CK73HB1A104K	CHIP C 0.10UF K	
C204			CK73HB1E223K	CHIP C 0.022UF K		C314			CC73HCH1H101J	CHIP C 100PF J	
C205			CK73HB1A104K	CHIP C 0.10UF K		C315			CK73FB1A106K	CHIP C 10UF K	
C206,207			CK73HB1H561K	CHIP C 560PF K		C316			CK73HB1A104K	CHIP C 0.10UF K	
C208			CK73HB1A104K	CHIP C 0.10UF K		C317			CK73HB1C103K	CHIP C 0.010UF K	
C209			CC73HCH1H220J	CHIP C 22PF J		C318			CC73HCH1H221J	CHIP C 220PF J	
C210			CK73HB1A104K	CHIP C 0.10UF K		C319			CK73HB1C103K	CHIP C 0.010UF K	
C211			CK73HB1C333K	CHIP C 0.033UF K		C320			CK73GB1E104K	CHIP C 0.10UF K	
C212,213			CK73HB1A104K	CHIP C 0.10UF K		C321			CK73HB1C103K	CHIP C 0.010UF K	
C214			CK73HB1C103K	CHIP C 0.010UF K		C322			CK73HB1H102K	CHIP C 1000PF K	
C215			CC73HCH1H220J	CHIP C 22PF J		C323			CK73HB1A104K	CHIP C 0.10UF K	
C216			CK73HB1C103K	CHIP C 0.010UF K		C324			CK73HB1A184K	CHIP C 0.18UF K	
C217			CC73HCH1H050C	CHIP C 5.0PF C		C325			CK73HB1E153K	CHIP C 0.015UF K	
C218			CK73HB1C103K	CHIP C 0.010UF K		C326			CK73HB1C123K	CHIP C 0.012UF K	
C219			CC73HCH1H220J	CHIP C 22PF J		C328			CK73HB1A184K	CHIP C 0.18UF K	
C220			CK73HB1H102K	CHIP C 1000PF K		C329			CK73HB1C333K	CHIP C 0.033UF K	
C221			CK73HB1C103K	CHIP C 0.010UF K		C330			CK73HB1H681K	CHIP C 680PF K	
C222			CC73HCH1H080D	CHIP C 8.0PF D		C332			CK73HB1C103K	CHIP C 0.010UF K	
C223			CC73HCH1H060B	CHIP C 6.0PF B		C333			CK73HB1H102K	CHIP C 1000PF K	
C224			CK73HB1C103K	CHIP C 0.010UF K		C334,335			CK73HB1A184K	CHIP C 0.18UF K	
C225			CC73HCH1H050C	CHIP C 5.0PF C		C336			CK73HB1C103K	CHIP C 0.010UF K	
C226			CK73HB1H102K	CHIP C 1000PF K		C337			CK73HB1A184K	CHIP C 0.18UF K	
C227			CK73HCH1C103K	CHIP C 0.010UF K		C338			CC73HCH1H331J	CHIP C 330PF J	
C228			CC73HCH1H100D	CHIP C 10PF D		C339			CK73HB1A563K	CHIP C 0.056UF K	
C229			CK73HB1C103K	CHIP C 0.010UF K		C340			CC73HCH1H100B	CHIP C 10PF B	
C230			CC73HCH1H050C	CHIP C 5.0PF C		C341			CK73HB1H332K	CHIP C 3300PF K	
C231			CC73HCH1H220J	CHIP C 22PF J		C342			CK73HB1C103K	CHIP C 0.010UF K	
C232			CC73HCH1H030B	CHIP C 3.0PF B		C343			CK73HB1A184K	CHIP C 0.18UF K	
C233			CK73HB1C103K	CHIP C 0.010UF K		C344			CK73HB1C273K	CHIP C 0.027UF K	
C234			CC73HCH1H101J	CHIP C 100PF J		C345			CK73HB1H102K	CHIP C 1000PF K	
C235,236			CK73HB1H102K	CHIP C 1000PF K		C346			CK73HB1A184K	CHIP C 0.18UF K	
C237			CC73HCH1H0R5B	CHIP C 0.5PF B		C347			CK73GB1A105K	CHIP C 1.0UF K	
C238			CC73HCH1H390J	CHIP C 39PF J		C349			CK73HB1C473K	CHIP C 0.047UF K	
C239			CK73HB1H102K	CHIP C 1000PF K		C350			CK73HB1H102K	CHIP C 1000PF K	

PARTS LIST

TX-RX UNIT (X57-8092-71)

Ref. No.	Address	New parts	Parts No.	Description	Destination	Ref. No.	Address	New parts	Parts No.	Description	Destination
C352			CK73HB1H102K	CHIP C 1000PF K		L206			L40-1285-71	SMALL FIXED INDUCTOR(120NH)	
C353			CK73GB1E105K	CHIP C 1.0UF K		L207,208			L41-8278-14	SMALL FIXED INDUCTOR(82NH)	
C354			CK73HB1A224K	CHIP C 0.22UF K		L209			L41-6878-14	SMALL FIXED INDUCTOR(68N)	
C355			CK73HB1A105K	CHIP C 1.0UF K		L210			L41-1878-14	SMALL FIXED INDUCTOR(18NH)	
C357,358			CK73HB1A104K	CHIP C 0.10UF K		L211			L40-5681-86	SMALL FIXED INDUCTOR(0.56UH)	
C360			CK73HB1A104K	CHIP C 0.10UF K		L212			L40-8281-86	SMALL FIXED INDUCTOR(0.82UH)	
C362			CK73HB1C123K	CHIP C 0.012UF K		L213			L40-5681-86	SMALL FIXED INDUCTOR(0.56UH)	
C400			CK73HB1A104K	CHIP C 0.10UF K		L215			L41-8278-14	SMALL FIXED INDUCTOR(82NH)	
C401			CK73HB1H102K	CHIP C 1000PF K		L500			L92-0149-05	CHIP FERRITE	
C402			CC73HCH1H120J	CHIP C 12PF J		X1			L77-3074-05	TCXO(19.2MHZ)	
C403			CC73HCH1H010B	CHIP C 1.0PF B		X400			L77-2974-05	CRYSTAL RESONATOR(11.0592MHZ)	
C404			CK73HB1A104K	CHIP C 0.10UF K		XF200			L71-0669-05	MCF(38.85MHZ)	
C405			CK73HB1H102K	CHIP C 1000PF K		R1			RK73HB1J105J	CHIP R 1.0M J 1/16W	
C406			CC73HCH1H120J	CHIP C 12PF J		R2			RK73HB1J103J	CHIP R 10K J 1/16W	
C407			CK73HB1H102K	CHIP C 1000PF K		R3			RK73HB1J222J	CHIP R 2.2K J 1/16W	
C408			CK73HB1C103K	CHIP C 0.010UF K		R5			RK73HB1J821J	CHIP R 820 J 1/16W	
C409			CK73HB1H102K	CHIP C 1000PF K		R9			RK73HB1J103J	CHIP R 10K J 1/16W	
C411-415			CK73HB1H102K	CHIP C 1000PF K		R11			RK73HB1J272J	CHIP R 2.7K J 1/16W	
C500			CC73HCH1H101J	CHIP C 100PF J		R12			RK73HB1J104J	CHIP R 100K J 1/16W	
C501,502			CK73HB1H102K	CHIP C 1000PF K		R13			RK73HB1J681J	CHIP R 680 J 1/16W	
C503			CK73FB1A475K	CHIP C 4.7UF K		R14			RK73HB1J103J	CHIP R 10K J 1/16W	
C504			CK73HB1H102K	CHIP C 1000PF K		R15			RK73HB1J104J	CHIP R 100K J 1/16W	
C505			CK73GB1E105K	CHIP C 1.0UF K		R16-22			RK73HB1J103J	CHIP R 10K J 1/16W	
C506			CK73HB1H102K	CHIP C 1000PF K		R23			RK73HB1J104J	CHIP R 100K J 1/16W	
C507			CK73FB1A106K	CHIP C 10UF K		R25			RK73HB1J100J	CHIP R 10 J 1/16W	
C511			CK73HB1H102K	CHIP C 1000PF K		R26			RK73HB1J392J	CHIP R 3.9K J 1/16W	
C513,514			CK73GB1E105K	CHIP C 1.0UF K		R27			RK73HB1J181J	CHIP R 180 J 1/16W	
C515,516			CK73HB1H102K	CHIP C 1000PF K		R28			RK73HB1J560J	CHIP R 56 J 1/16W	
C517			CK73FB1A475K	CHIP C 4.7UF K		R29			RK73HB1J472J	CHIP R 4.7K J 1/16W	
C522-524			CK73HB1H102K	CHIP C 1000PF K		R30			RK73HB1J221J	CHIP R 220 J 1/16W	
J300	2B		E11-0484-05	3.5D PHONE JACK(3.5D/MIC)		R32			RK73HB1J102J	CHIP R 1.0K J 1/16W	
J301	2B		E11-0717-05	2.5D PHONE JACK(2.5D/SP)		R33			RK73HB1J473J	CHIP R 47K J 1/16W	
F101			F53-0287-05	FUSE(0.5A)		R34			RK73HB1J100J	CHIP R 10 J 1/16W	
F300			F53-0467-05	FUSE(0.315A)		R37			RK73HB1J562J	CHIP R 5.6K J 1/16W	
F500			F53-0372-05	FUSE(3.15A)		R38			RK73HB1J332J	CHIP R 3.3K J 1/16W	
101	2A		J30-1308-04	SPACER(MIC)		R39			RK73HB1J331J	CHIP R 330 J 1/16W	
CF200	2A		L72-1046-05	CERAMIC FILTER(450KHZ)		R40			RK73HB1J332J	CHIP R 3.3K J 1/16W	
CD200	2A		L79-1914-05	TUNING COIL(450KHZ)		R41			RK73HB1J100J	CHIP R 10 J 1/16W	
L1			L40-4791-86	SMALL FIXED INDUCTOR(4.7UH)		R42			RK73HB1J332J	CHIP R 3.3K J 1/16W	
L2			L41-1885-45	SMALL FIXED INDUCTOR(180NH)		R43			RK73HB1J103J	CHIP R 10K J 1/16W	
L3 ,4			L41-2278-14	SMALL FIXED INDUCTOR(22NH)		R45			RK73HB1J000J	CHIP R 0 J 1/16W	
L5 ,6			L40-1001-86	SMALL FIXED INDUCTOR(10UH)		R50			RK73HB1J104J	CHIP R 100K J 1/16W	
L7			L40-1285-71	SMALL FIXED INDUCTOR(120NH)		R51			RK73HB1J333J	CHIP R 33K J 1/16W	
L8			L40-2775-71	SMALL FIXED INDUCTOR(27NH)		R52			RK73HB1J102J	CHIP R 1.0K J 1/16W	
L9			L40-8275-71	SMALL FIXED INDUCTOR(82NH)		R100			RK73HB1J472J	CHIP R 4.7K J 1/16W	
L100			L40-6875-71	SMALL FIXED INDUCTOR(68NH)		R101			RK73HB1J102J	CHIP R 1.0K J 1/16W	
L101			L40-1085-71	SMALL FIXED INDUCTOR(100NH)		R102			RK73HB1J222J	CHIP R 2.2K J 1/16W	
L102			L40-2775-71	SMALL FIXED INDUCTOR(27NH)		R103			RK73HB1J220J	CHIP R 22 J 1/16W	
L103			L41-8275-53	SMALL FIXED INDUCTOR(82NH)		R104			RK73HB1J331J	CHIP R 330 J 1/16W	
L104			L34-4577-05	AIR-CORE COIL(9T)		R105			RK73HB1J180J	CHIP R 18 J 1/16W	
L105			L34-4571-05	AIR-CORE COIL(3T)		R106			RK73HB1J104J	CHIP R 100K J 1/16W	
L106,107			L34-4573-05	AIR-CORE COIL(5T)		R107			RK73HB1J100J	CHIP R 10 J 1/16W	
L108			L34-4574-05	AIR-CORE COIL(6T)		R108			RK73HB1J104J	CHIP R 100K J 1/16W	
L109			L41-2295-52	SMALL FIXED INDUCTOR(2.2UH)		R109			RK73HB1J470J	CHIP R 47 J 1/16W	
L110-112			L34-4577-05	AIR-CORE COIL(9T)		R111			RK73HB1J683J	CHIP R 68K J 1/16W	
L203			L40-2763-71	SMALL FIXED INDUCTOR(2.7NH)		R112			RK73HB1J470J	CHIP R 47 J 1/16W	
L204			L41-8285-14	SMALL FIXED INDUCTOR(820NH)		R113			RK73HB1J563J	CHIP R 56K J 1/16W	
L205			L40-2275-71	SMALL FIXED INDUCTOR(22NH)		R114			RK73GB2A000J	CHIP R 0 J 1/10W	
						R115			RK73FB2B000J	CHIP R 0 J 1/8W	

PARTS LIST

TX-RX UNIT (X57-8092-71)

Ref. No.	Address	New parts	Parts No.	Description	Desti-nation	Ref. No.	Address	New parts	Parts No.	Description	Desti-nation
R116			RK73HB1J393J	CHIP R 39K J 1/16W		R323			RK73HB1J562J	CHIP R 5.6K J 1/16W	
R117			RK73HB1J271J	CHIP R 270 J 1/16W		R324,325			RK73HH1J473D	CHIP R 47K D 1/16W	
R119			RK73HB1J271J	CHIP R 270 J 1/16W		R326			RK73HB1J000J	CHIP R 0 J 1/16W	
R120			RK73HB1J331J	CHIP R 330 J 1/16W		R327			RK73HB1J824J	CHIP R 820K J 1/16W	
R121-123			RK73EB2ER39K	CHIP R 0.39 K 1/4W		R328			RK73HB1J684J	CHIP R 680K J 1/16W	
R136			RK73HB1J182J	CHIP R 1.8K J 1/16W		R329,330			RK73HB1J103J	CHIP R 10K J 1/16W	
R155			RK73HB1J180J	CHIP R 18 J 1/16W		R331			RK73HB1J473J	CHIP R 47K J 1/16W	
R200			RK73HB1J103J	CHIP R 10K J 1/16W		R332			RK73HB1J272J	CHIP R 2.7K J 1/16W	
R201			RK73HB1J470J	CHIP R 47 J 1/16W		R334			RK73HB1J103J	CHIP R 10K J 1/16W	
R202			RK73HB1J561J	CHIP R 560 J 1/16W		R336			RK73HB1J823J	CHIP R 82K J 1/16W	
R203			RK73HB1J273J	CHIP R 27K J 1/16W		R337			RK73HB1J000J	CHIP R 0 J 1/16W	
R204			RK73HB1J271J	CHIP R 270 J 1/16W		R340			RK73HB1J103J	CHIP R 10K J 1/16W	
R205			RK73HB1J682J	CHIP R 6.8K J 1/16W		R342			RK73HB1J153J	CHIP R 15K J 1/16W	
R206			RK73HB1J274J	CHIP R 270K J 1/16W		R344			RK73HB1J103J	CHIP R 10K J 1/16W	
R207			RK73HB1J562J	CHIP R 5.6K J 1/16W		R345			RK73HB1J561J	CHIP R 560 J 1/16W	
R208			RK73HB1J101J	CHIP R 100 J 1/16W		R347			RK73HB1J103J	CHIP R 10K J 1/16W	
R209			RK73HB1J470J	CHIP R 47 J 1/16W		R348			RK73HB1J183J	CHIP R 18K J 1/16W	
R210			RK73HB1J334J	CHIP R 330K J 1/16W		R350			RK73HB1J471J	CHIP R 470 J 1/16W	
R211			RK73HB1J000J	CHIP R 0 J 1/16W		R351			RK73HB1J561J	CHIP R 560 J 1/16W	
R212			RK73HB1J184J	CHIP R 180K J 1/16W		R352			RK73HB1J104J	CHIP R 100K J 1/16W	
R213			RK73HB1J102J	CHIP R 1.0K J 1/16W		R353			RK73HB1J102J	CHIP R 1.0K J 1/16W	
R214			RK73HB1J681J	CHIP R 680 J 1/16W		R354			RK73HB1J334J	CHIP R 330K J 1/16W	
R215			RK73HB1J331J	CHIP R 330 J 1/16W		R355			RK73HB1J473J	CHIP R 47K J 1/16W	
R216			RK73HB1J470J	CHIP R 47 J 1/16W		R356			RK73HB1J183J	CHIP R 18K J 1/16W	
R217			RK73FB2B000J	CHIP R 0 J 1/8W		R357			RK73HB1J564J	CHIP R 560K J 1/16W	
R218			RK73HB1J102J	CHIP R 1.0K J 1/16W		R358			RK73HB1J473J	CHIP R 47K J 1/16W	
R219			RK73HB1J332J	CHIP R 3.3K J 1/16W		R360			RK73HB1J184J	CHIP R 180K J 1/16W	
R220			RK73HB1J331J	CHIP R 330 J 1/16W		R361			RK73HB1J561J	CHIP R 560 J 1/16W	
R221			RK73HB1J823J	CHIP R 82K J 1/16W		R363			RK73HB1J562J	CHIP R 5.6K J 1/16W	
R222			RK73HB1J104J	CHIP R 100K J 1/16W		R364			RK73HB1J471J	CHIP R 470 J 1/16W	
R223,224			RK73HB1J823J	CHIP R 82K J 1/16W		R365			RK73HB1J000J	CHIP R 0 J 1/16W	
R225			RK73HB1J101J	CHIP R 100 J 1/16W		R366			RK73HB1J104J	CHIP R 100K J 1/16W	
R226,227			RK73HB1J105J	CHIP R 1.0M J 1/16W		R367			RK73HB1J473J	CHIP R 47K J 1/16W	
R228			RK73HB1J470J	CHIP R 47 J 1/16W		R369			RK73HB1J103J	CHIP R 10K J 1/16W	
R229			RK73HB1J152J	CHIP R 1.5K J 1/16W		R370			RK73HH1J473D	CHIP R 47K D 1/16W	
R230			RK73HB1J181J	CHIP R 180 J 1/16W		R371			RK73HB1J822J	CHIP R 8.2K J 1/16W	
R231			RK73HB1J471J	CHIP R 470 J 1/16W		R372			RK73HH1J473D	CHIP R 47K D 1/16W	
R232			RK73HB1J124J	CHIP R 120K J 1/16W		R374			RK73HH1J473D	CHIP R 47K D 1/16W	
R233			RK73HB1J104J	CHIP R 100K J 1/16W		R375			RK73HB1J103J	CHIP R 10K J 1/16W	
R234			RK73HB1J184J	CHIP R 180K J 1/16W		R376			RK73HH1J473D	CHIP R 47K D 1/16W	
R236,237			RK73HB1J105J	CHIP R 1.0M J 1/16W		R377			RK73HB1J393J	CHIP R 39K J 1/16W	
R260			RK73HB1J273J	CHIP R 27K J 1/16W		R378			RK73HB1J102J	CHIP R 1.0K J 1/16W	
R262			RK73HB1J274J	CHIP R 270K J 1/16W		R379			RK73HB1J104J	CHIP R 100K J 1/16W	
R264			RK73HB1J394J	CHIP R 390K J 1/16W		R386			RK73HB1J392J	CHIP R 3.9K J 1/16W	
R267			RK73HB1J820J	CHIP R 82 J 1/16W		R388			RK73HB1J822J	CHIP R 8.2K J 1/16W	
R268			RK73HB1J271J	CHIP R 270 J 1/16W		R389			RK73HB1J102J	CHIP R 1.0K J 1/16W	
R300			RK73HB1J152J	CHIP R 1.5K J 1/16W		R392,393			RK73HB1J102J	CHIP R 1.0K J 1/16W	
R301			RK73HB1J101J	CHIP R 100 J 1/16W		R394			RK73HB1J000J	CHIP R 0 J 1/16W	
R302			RK73HB1J102J	CHIP R 1.0K J 1/16W		R396			RK73HB1J332J	CHIP R 3.3K J 1/16W	
R303			RK73HB1J471J	CHIP R 470 J 1/16W		R397			RK73HB1J473J	CHIP R 47K J 1/16W	
R304			RK73HB1J473J	CHIP R 47K J 1/16W		R400			RK73HB1J472J	CHIP R 4.7K J 1/16W	
R305-308			RK73HB1J102J	CHIP R 1.0K J 1/16W		R401			RK73HB1J102J	CHIP R 1.0K J 1/16W	
R309			RK73HB1J182J	CHIP R 1.8K J 1/16W		R406			RK73HB1J101J	CHIP R 100 J 1/16W	
R310,311			RK73HB1J102J	CHIP R 1.0K J 1/16W		R407			RK73HB1J473J	CHIP R 47K J 1/16W	
R312			RK73HB1J222J	CHIP R 2.2K J 1/16W		R408			RK73HB1J101J	CHIP R 100 J 1/16W	
R313-315			RK73HB1J103J	CHIP R 10K J 1/16W		R409			RK73GB2A221J	CHIP R 220 J 1/10W	
R317			RK73HB1J334J	CHIP R 330K J 1/16W		R410			RK73GB2A271J	CHIP R 270 J 1/10W	
R318			RK73HB1J274J	CHIP R 270K J 1/16W		R411,412			RK73HB1J472J	CHIP R 4.7K J 1/16W	
R321			RK73HB1J474J	CHIP R 470K J 1/16W		R413			RK73HB1J102J	CHIP R 1.0K J 1/16W	
R322			RK73HB1J105J	CHIP R 1.0M J 1/16W		R414			RK73HB1J474J	CHIP R 470K J 1/16W	

PARTS LIST

TX-RX UNIT (X57-8092-71)

Ref. No.	Address	New parts	Parts No.	Description	Destination	Ref. No.	Address	New parts	Parts No.	Description	Destination
R438			RK73HB1J473J	CHIP R 47K J 1/16W		Q306			2SK3577-A	FET	
R455			RK73HB1J102J	CHIP R 1.0K J 1/16W		Q400			2SC4919-S	TRANSISTOR	
R472			RK73HB1J000J	CHIP R 0 J 1/16W		Q401,402			LTC014YEBFS8	TRANSISTOR	
R502			RK73HB1J334J	CHIP R 330K J 1/16W		Q403		*	SSM6L35FU-F	FET	
R505			RK73HB1J473J	CHIP R 47K J 1/16W		Q500			MCH3309-H	FET	
R508			RK73HB1J473J	CHIP R 47K J 1/16W		Q501			SSM3J05FU-F	FET	
R509			RK73HB1J104J	CHIP R 100K J 1/16W		Q502			LTA023JEBFS8	TRANSISTOR	
R511			RK73HB1J334J	CHIP R 330K J 1/16W							
R512			RK73GB2A271J	CHIP R 270 J 1/10W		TH100			B57331V2104J	THERMISTOR(100K)	
VR500	2B		R31-0684-05	VARIABLE RESISTOR		TH260			B57331V2104J	THERMISTOR(100K)	
S400	2B		S70-0414-05	TACT SWITCH							
S401			S70-0514-05	TACT SWITCH							
S402	2B		S60-0447-05	ROTARY SWITCH							
MIC300	2A		T91-0674-05	MIC ELEMENT							
D1			DA2S101	DIODE							
D2 ,3			1SV325F	VARIABLE CAPACITANCE DIODE							
D4			HSC277	DIODE							
D5 ,6			HVC350B	VARIABLE CAPACITANCE DIODE							
D7			DA2S101	DIODE							
D100			HSC277	DIODE							
D101,102			HVC131	DIODE							
D103			RN142S	DIODE							
D200			HSC277	DIODE							
D201-204			HVC350B	VARIABLE CAPACITANCE DIODE							
D301			KDR731	DIODE							
D380			DZ2S068(M)	ZENER DIODE							
D402			DA2S101	DIODE							
D500			GN1G	DIODE							
D501			KDR720E-P	DIODE							
IC1			MB15E03SL-E1	MOS-IC							
IC200			NJM2591V	BI-POLAR IC							
IC300			R2A20178NP	DAC IC							
IC301			BA2904FVM	MOS-IC							
IC302			TA7368PL	MOS-IC							
IC303-305			NJM12904RB1	MOS-IC							
IC400			F2136ACNKDRB	MCU							
IC401			EX24016ATAS0A	ROM IC							
IC500			XC6120N302N-G	MOS-IC							
IC501			XC6209B502P-G	MOS-IC							
IC503			XC6209B502P-G	MOS-IC							
Q1 ,2			LTC014EEBFS8	TRANSISTOR							
Q3			DSC90010(S)	TRANSISTOR							
Q4			MCH3914(7)-H	FET							
Q5			2SC5488A-H	TRANSISTOR							
Q6			2SC5636	TRANSISTOR							
Q7			DSC90010(S)	TRANSISTOR							
Q100			2SC4926YD	TRANSISTOR							
Q101			RFM01U7P	FET							
Q102			RD07MUS2BT112	FET							
Q103			LTC014EEBFS8	TRANSISTOR							
Q200			LTA023JEBFS8	TRANSISTOR							
Q201,202			KTC4080E-P	TRANSISTOR							
Q203			3SK318	FET							
Q205			3SK294-FP	FET							
Q300,301			LTC044EEBFS8	TRANSISTOR							
Q302			2SK3577-A	FET							
Q303			SSM6J08FU(F)	FET							
Q304			LTA023JEBFS8	TRANSISTOR							
Q305			LTC014YEBFS8	TRANSISTOR							

EXPLODED VIEW

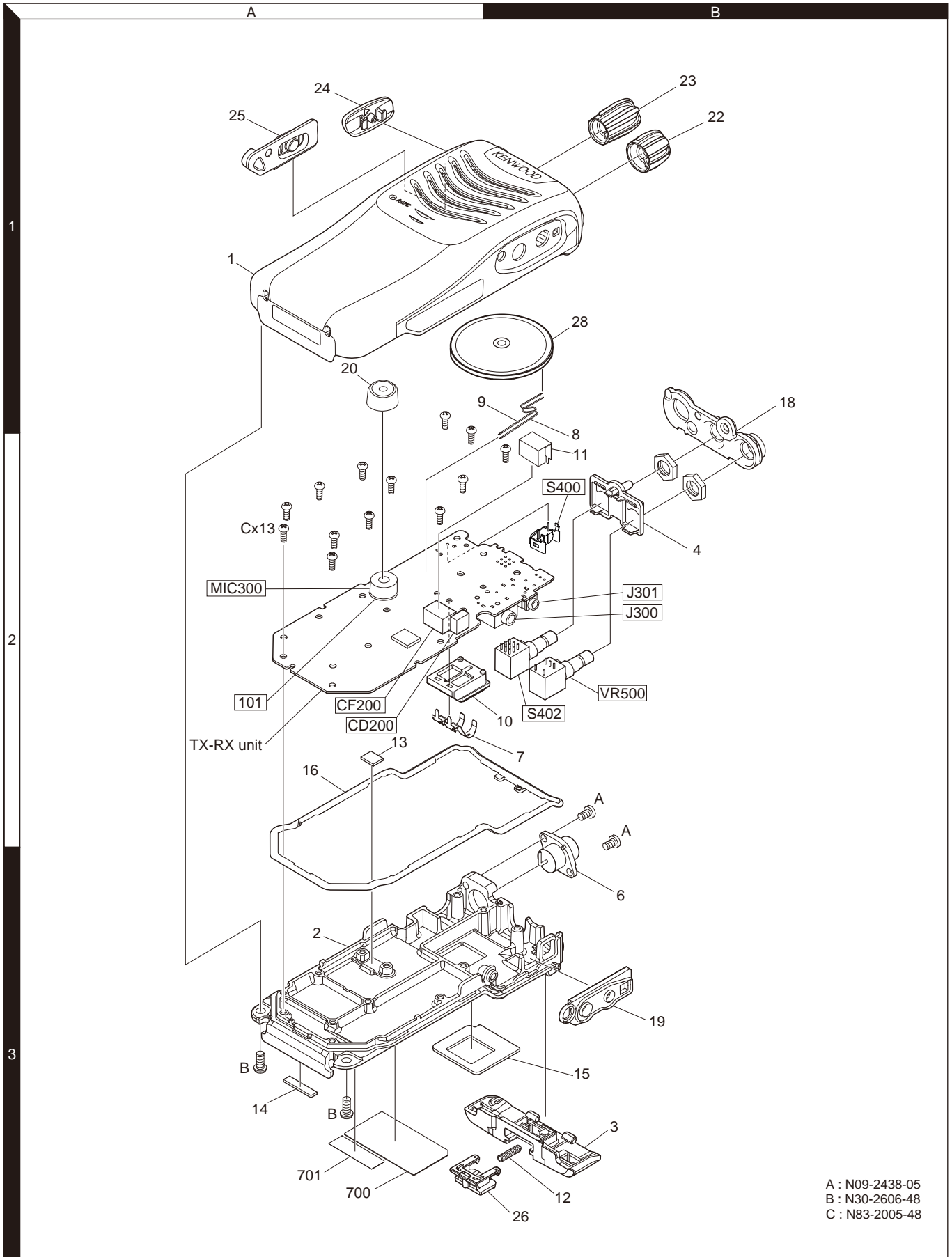

A : N09-2438-05
 B : N30-2606-48
 C : N83-2005-48

Parts with the exploded numbers larger than 700 are not supplied.

If a part reference number is listed in a box on the exploded view of the PCB, that part does not come with the PCB. These parts must be ordered separately.

ADJUSTMENT

Test Equipment Required for Alignment

Test Equipment	Major Specifications	
1. Standard Signal Generator (SSG)	Frequency Range Modulation Output	136 to 174MHz Frequency modulation and external modulation -127dBm/0.1 μ V to greater than -47dBm/1mV
2. RF Power Meter	Input Impedance Operation Frequency Measurement Range	50 Ω 136 to 174MHz Vicinity of 10W
3. Deviation Meter	Frequency Range	136 to 174MHz
4. Digital Volt Meter (DVM)	Measuring Range Input Impedance	10mV to 10V DC High input impedance for minimum circuit loading
5. Oscilloscope		DC through 30MHz
6. High Sensitivity Frequency Counter	Frequency Range Frequency Stability	10Hz to 1000MHz 0.2ppm or less
7. DC Ammeter		5A
8. AF Volt Meter (AF VM)	Frequency Range Voltage Range	50Hz to 10kHz 1mV to 10V
9. Audio Generator (AG)	Frequency Range Output	50Hz to 5kHz or more 0 to 1V
10. Distortion Meter	Capability Input Level	3% or less at 1kHz 50mV to 10Vrms
11. Spectrum Analyzer	Measuring Range	10kHz to 1GHz or more
12. Tracking Generator	Center frequency Output Voltage	50kHz to 600MHz 100mV or more
13. 8 Ω Dummy Load		Approx. 8 Ω , 3W
14. Regulated Power Supply		5V to 10V, approx. 3A Useful if ammeter equipped

■ Antenna connector adapter

The antenna connector of this transceiver uses an SMA terminal.

Use an antenna connector adapter [SMA(f) – BNC(f) or SMA(f) – N(f)] for adjustment. (The adapter is not provided as an option, so buy a commercially-available one.)

■ DC Supply

BATT+, BATT- : External power supply terminal (Fasten it with an alligator clip.)

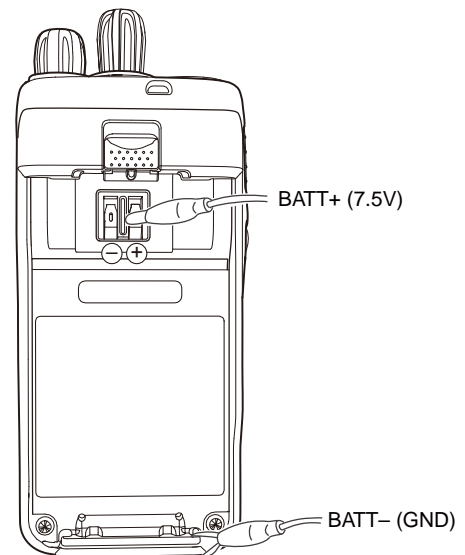

ADJUSTMENT

Frequency and Signaling

The transceiver has been adjusted for the frequencies shown in the following table. When required, re-adjust them following the adjustment procedure to obtain the frequencies you want in actual operation.

■ Test Frequency (MHz)

CH	RX Frequency	TX Frequency
1	155.05000	155.10000
2	136.05000	136.10000
3	173.95000	173.90000
4	155.00000	155.00000
5	155.20000	155.20000
6	155.40000	155.40000
7-16	-	-

■ Signaling

No.	RX (Decode)	TX (Encode)
1	None	None
2	None	100Hz Square Wave
3	QT 67.0Hz	QT 67.0Hz
4	QT 151.4Hz	QT 151.4Hz
5	QT 210.7Hz	QT 210.7Hz
6	QT 254.1Hz	QT 254.1Hz
7	DQT D023N	DQT D023N
8	DQT D754I	DQT D754I
9	None	DTMF (Code: 159D)
10	None	DTMF (Code: 9)

Preparations for Tuning the Transceiver

Before attempting to tune the transceiver, connect the unit to a suitable power supply.

Whenever the transmitter is tuned, the unit must be connected to a suitable dummy load (i.e. power meter).

The speaker output connector must be terminated with a 8Ω dummy load and connected to an AC voltmeter and an audio distortion meter or a SINAD measurement meter at all times during tuning.

■ Adjustment frequency (MHz)

Tuning point	RX	TX
Low	136.05000	136.10000
Center	155.05000	155.10000
High	173.95000	173.90000

Adjustment Points

TX-RX UNIT

Component side view

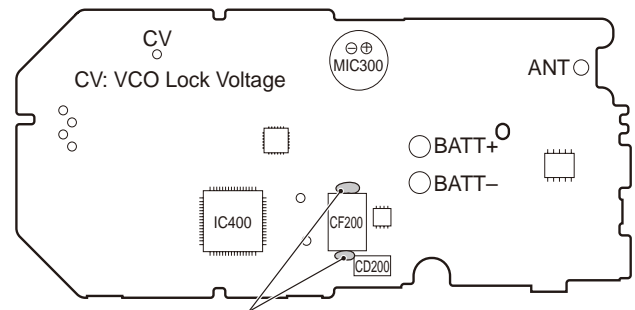

Note: When replacing CF200, apply bond to the point shown in the figure.

Foil side view

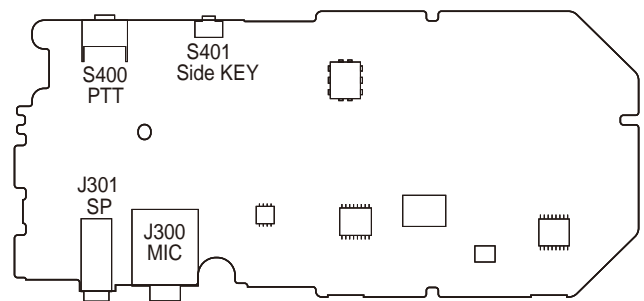

ADJUSTMENT

Common Section

Item	Condition	Measurement			Adjustment			Specifications / Remarks
		Test-equipment	Unit	Terminal	Unit	Parts	Method	
1. Setting	1) BATT terminal voltage: 7.5V 2) SSG standard modulation [Wide] MOD: 1kHz, DEV: 3kHz [Narrow] MOD: 1kHz, DEV: 1.5kHz							
2. VCO Lock Voltage	1) Adj item: High	Power meter	TX-RX	ANT (CV)		FPU	4.0V	±0.1V

Transmitter Section

Item	Condition	Measurement			Adjustment			Specifications / Remarks
		Test-equipment	Unit	Terminal	Unit	Parts	Method	
1. Frequency	1) Adj item: High Press [Transmit] button.	f. counter	TX-RX	ANT		FPU	173.900MHz	±50Hz
2. High Transmit Power and Protective Current *Note	1) Adj item: Low, Center, High (3 points) BATT terminal voltage: 7.5V Press [Transmit] button.	Power meter Ammeter	TX-RX	ANT SP/MIC connector		FPU	4.8W	±0.1W 2.0A or less
3. Low Transmit Power	1) Adj item: Low, Center, High (3 points) BATT terminal voltage: 7.5V Press [Transmit] button.						1.0W	±0.1W 1.0A or less
4. DQT Balance [Wide]	1) Adj item: Low, Center, High (3 points) (Signaling Square Wave) Deviation meter filter LPF: 3kHz HPF: OFF Press [Transmit] button.	Power meter Deviation meter Oscilloscope AG AF VM	TX-RX	ANT SP/MIC connector		FPU	Make the modulation wave into square waves.	
5. Maximum Deviation [Wide]	1) Adj item: Center, Low, High (3 points) AG: 1kHz/150mV Deviation meter filter LPF: 15kHz HPF: OFF Press [Transmit] button.						4.0kHz (According to the lager +, -)	±100Hz
6. Battery Warning Level	1) BATT terminal voltage: 5.9V	DVM	TX-RX	BATT terminal		FPU	Write	BATT terminal voltage: 5.9V
7. Battery Detection Check (User mode)	1) BATT terminal voltage: 5.7V PTT: ON	Power meter DVM		ANT BATT terminal			Check	LED blinks No transmit power
	2) BATT terminal voltage: 7.5V PTT: ON							LED does not blink

- It is not necessary to adjust the fixed values for the DTMF-DEV, DQT-DEV, QT-DEV, and MIC sensitivity.
- The TX-DEV Narrow setting uses the Wide calculated adjustment level value.

***Note:** Please do not adjust High Transmit power without connecting TX Power meter or 50 ohm dummy load to the ANT terminal.

ADJUSTMENT

Receiver Section

Item	Condition	Measurement			Adjustment			Specifications / Remarks
		Test-equipment	Unit	Terminal	Unit	Parts	Method	
1. Sensitivity Check [Narrow]	1) Adj item: Low, High (2 points) SSG output: -116dBm (0.35μV) SSG DEV: 1.5kHz	SSG DVM Oscilloscope AF VM	TX-RX	ANT SP/MIC connector			Check	12dB SINAD or more
[Wide]	2) TEST CH: 1 SSG output: -118dBm (0.28μV) SSG DEV: 3.0kHz							
2. Squelch Level 5 Write [Wide]	1) Adj item: Low, Center, High (3 points) SSG output: -118dBm (0.28μV) SSG DEV: 3.0kHz					FPU	Write 1-1) Press [Band Pass Filter] button to store the adjustment value. 1-2) Press [Apply] button to store the adjustment value.	
[Narrow]	2) Adj item: Low, Center, High (3 points) SSG output: -117dBm (0.32μV) SSG DEV: 1.5kHz						2) Press [Apply] button to store the adjustment value.	
<ul style="list-style-type: none"> The Squelch Level 9 setting uses the Squelch Level 5 calculated adjustment level value. 								

TK-2000 PC BOARD

TX-RX UNIT (X57-8092-71) Component side view (J79-0362-29)

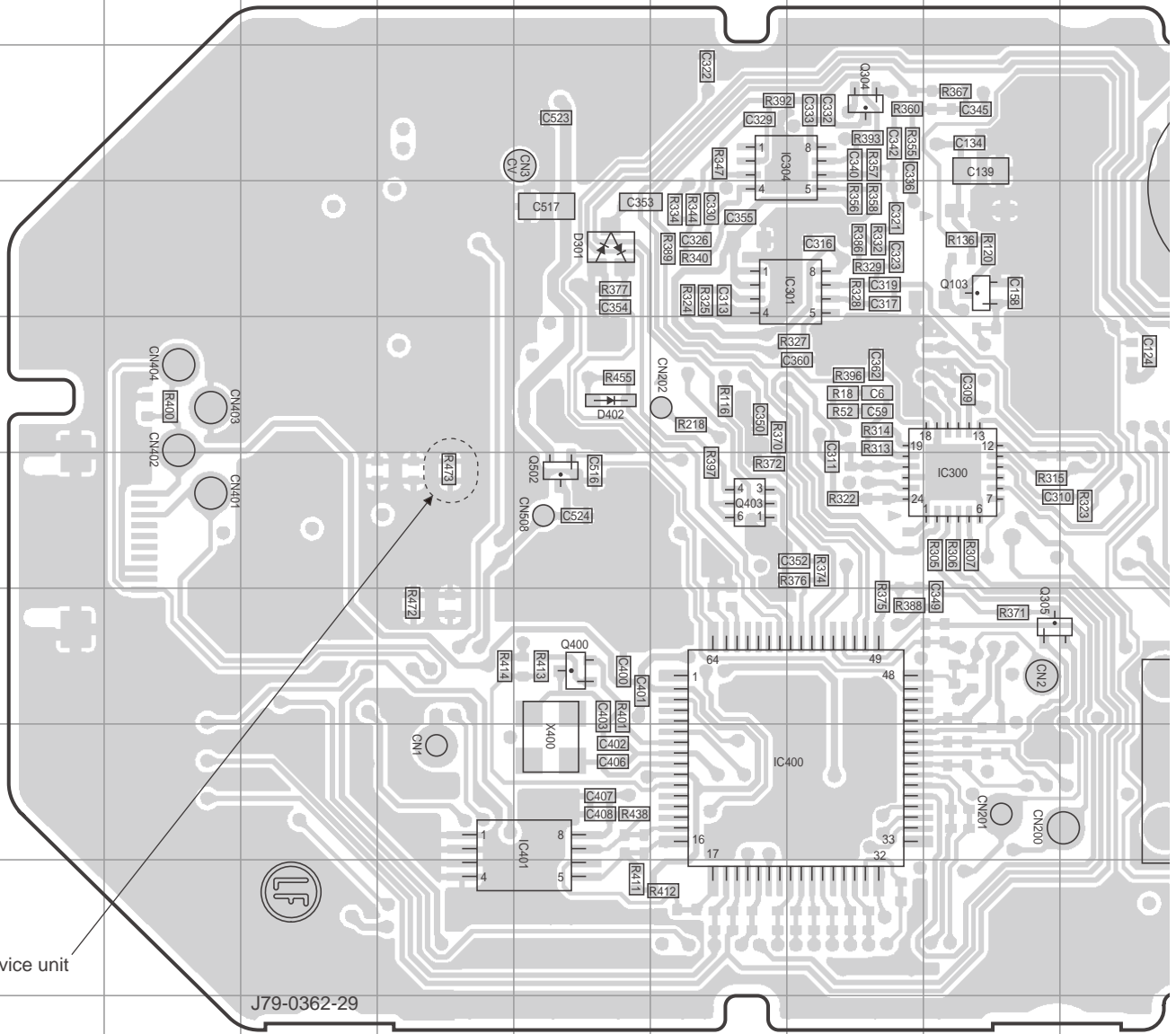

Note : for service unit

J79-0362-29

Ref. No.	Address	Ref. No.	Address	Ref. No.	Address
IC300	6I	Q103	4I	Q501	3N
IC301	4H	Q300	4O	Q500	5M
IC302	6P	Q301	4P	Q502	6F
IC303	8L	Q302	5P	D301	4F
IC304	3H	Q303	7P	D380	9O
IC400	8H	Q304	3H	D400	8R
IC401	8F	Q305	7I	D401	8R
IC500	4M	Q306	5P	D402	5F
IC501	4M	Q400	7F	D500	6K
IC503	4O	Q403	6G	D501	5O

PC BOARD TK-2000

TX-RX UNIT (X57-8092-71) Component side view (J79-0362-29)

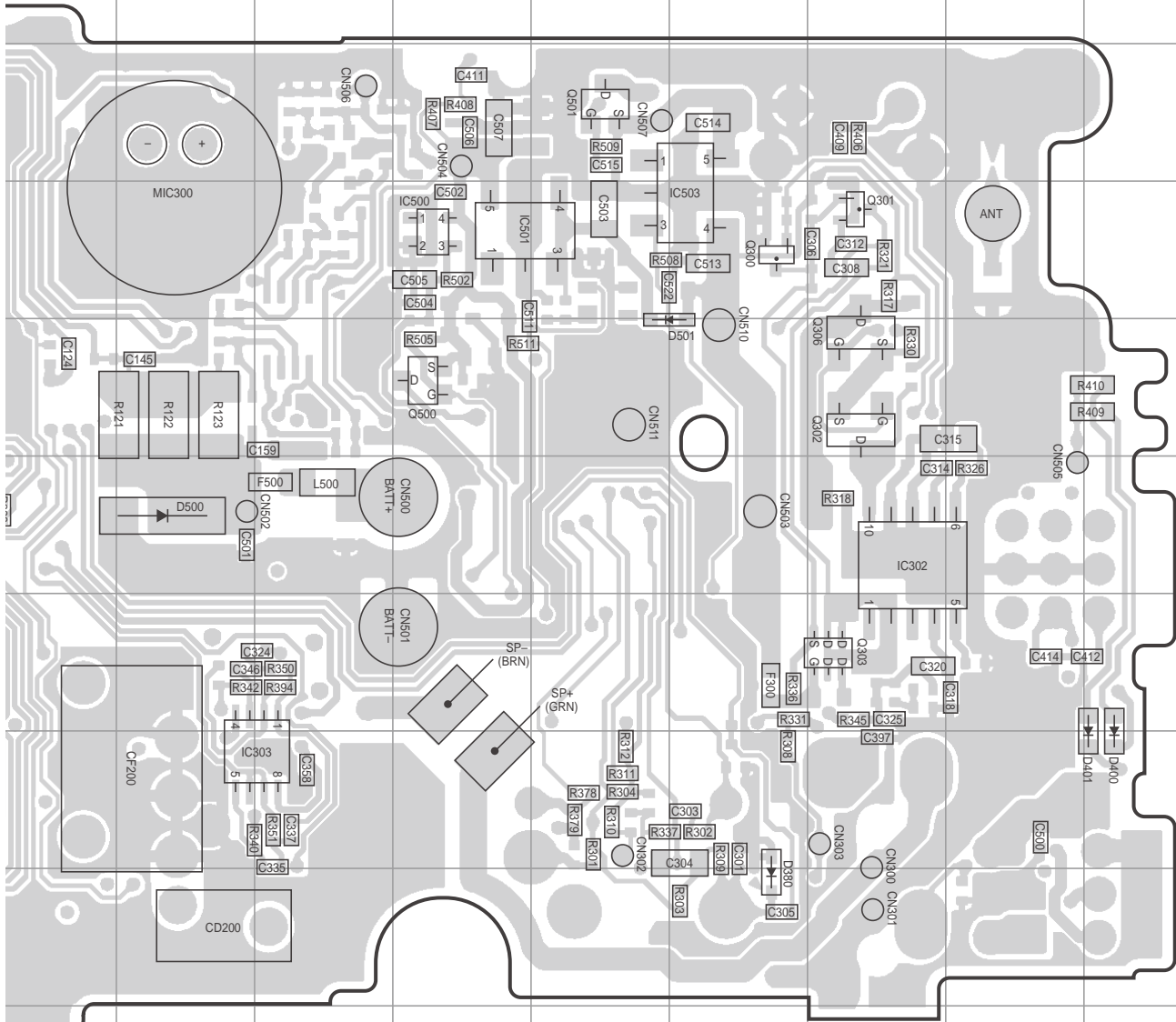

Component side

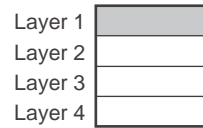

TK-2000 PC BOARD

TX-RX UNIT (X57-8092-71) Foil side view (J79-0362-29)

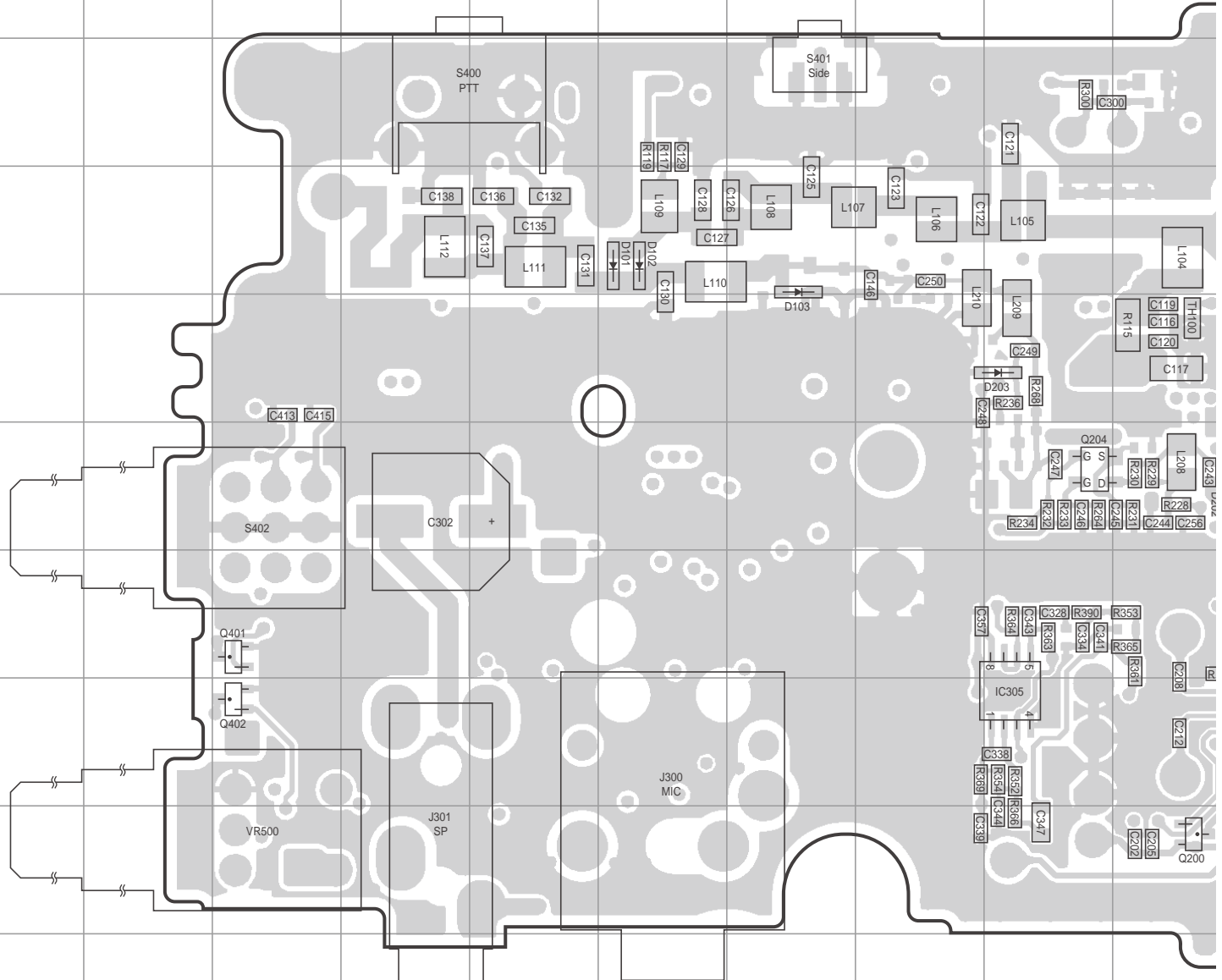

Ref. No.	Address	Ref. No.	Address	Ref. No.	Address	Ref. No.	Address
IC1	8P	Q7	9P	Q401	7C	D100	5N
IC200	8K	Q100	4M	Q402	8C	D101	4F
IC305	8I	Q101	5L	D1	4P	D102	4F
Q1	7P	Q102	4K	D2	4O	D103	5G
Q2	4O	Q200	9J	D3	4O	D200	6O
Q3	5O	Q201	9N	D4	4N	D201	6K
Q4	5P	Q202	8L	D5	4O	D202	6J
Q5	5P	Q203	6M	D6	4O	D203	5I
Q6	6O	Q204	6I	D7	5O	D204	6L

TK-2000 SCHEMATIC DIAGRAM

TX-RX UNIT(X57-8092-71)

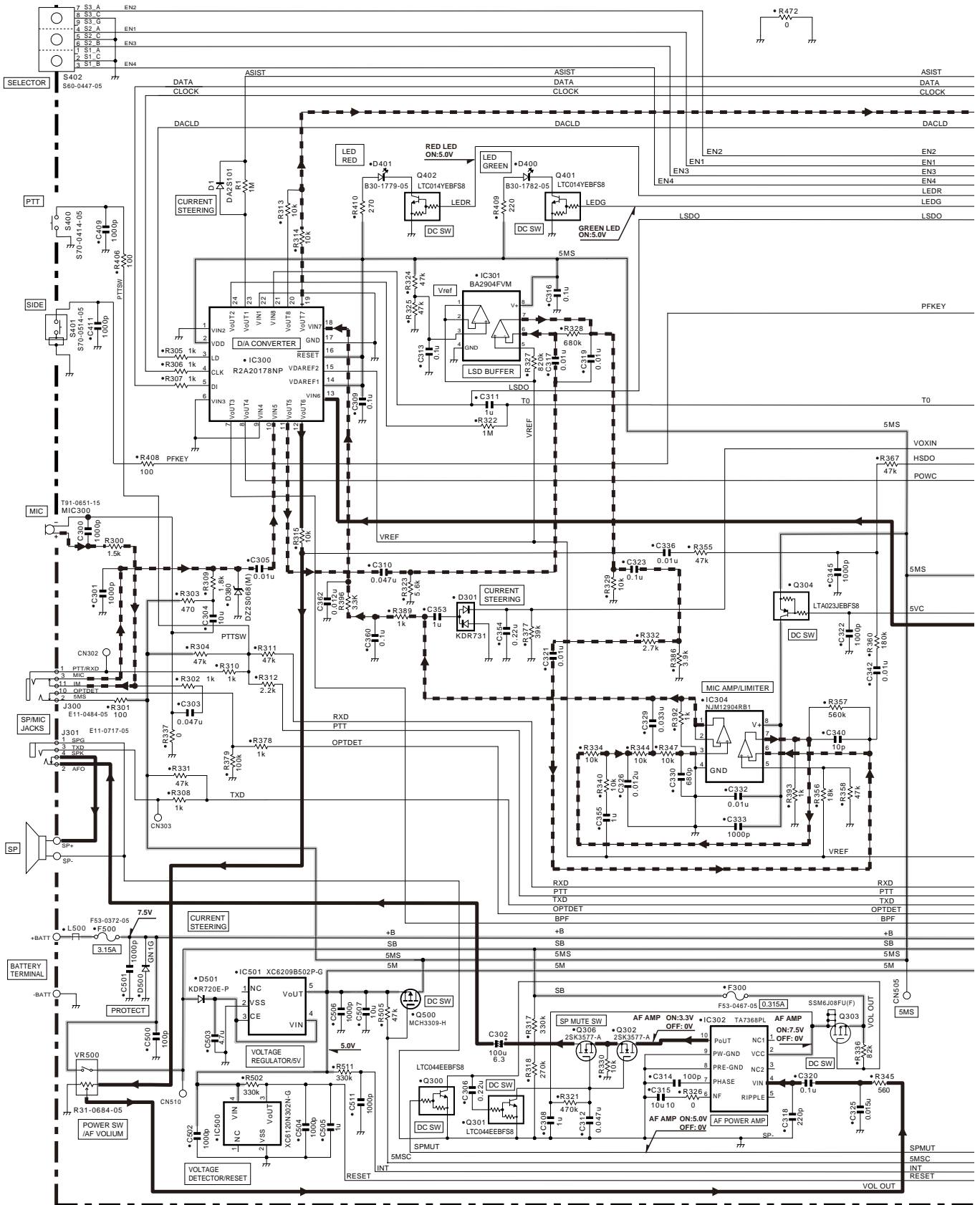

TK-2000 SCHEMATIC DIAGRAM

TX-RX UNIT(X57-8092-71)

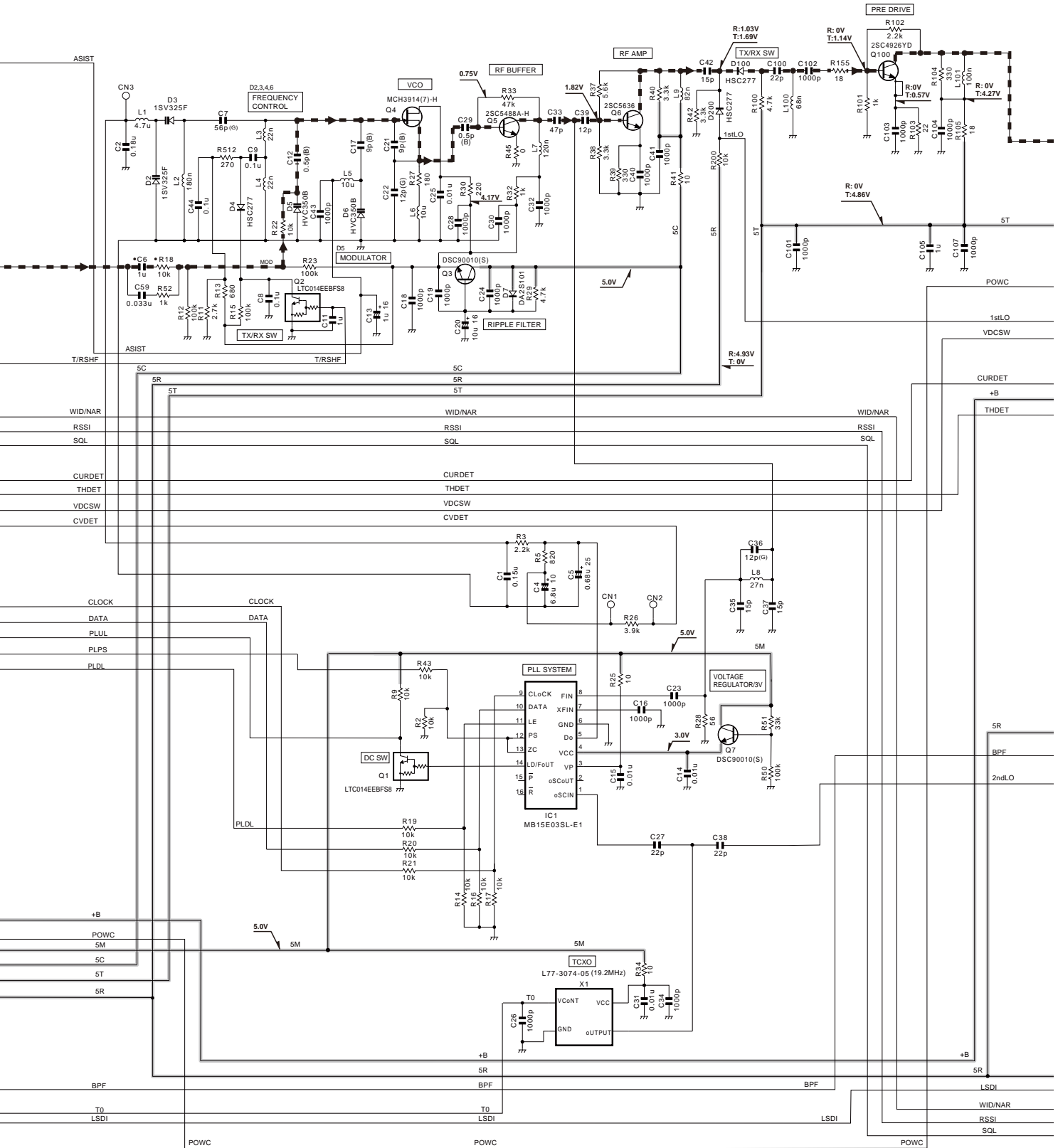

SCHEMATIC DIAGRAM TK-2000

TX-RX UNIT(X57-8092-71)

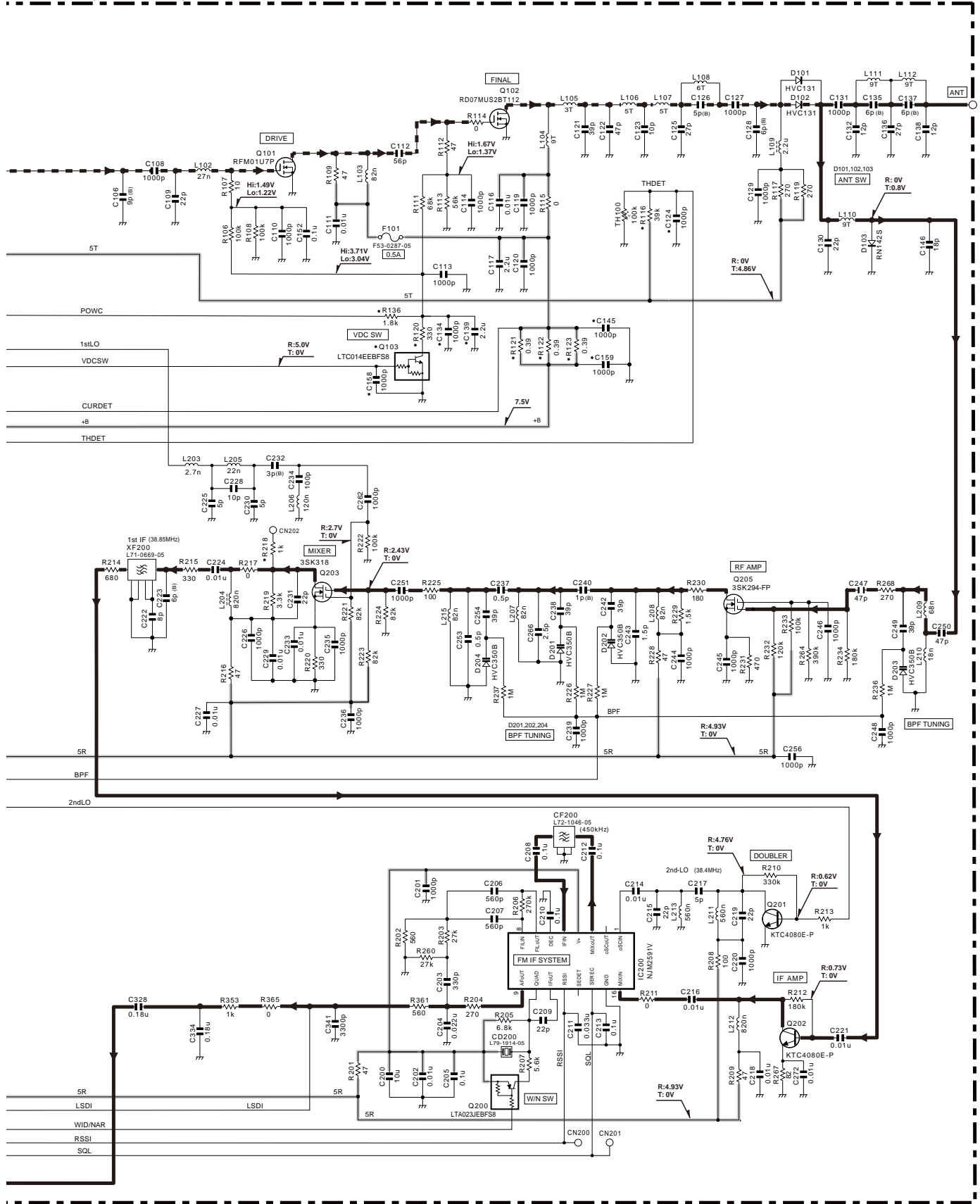

Note : The components marked with a dot (•) are parts of layer 1.

BLOCK DIAGRAM

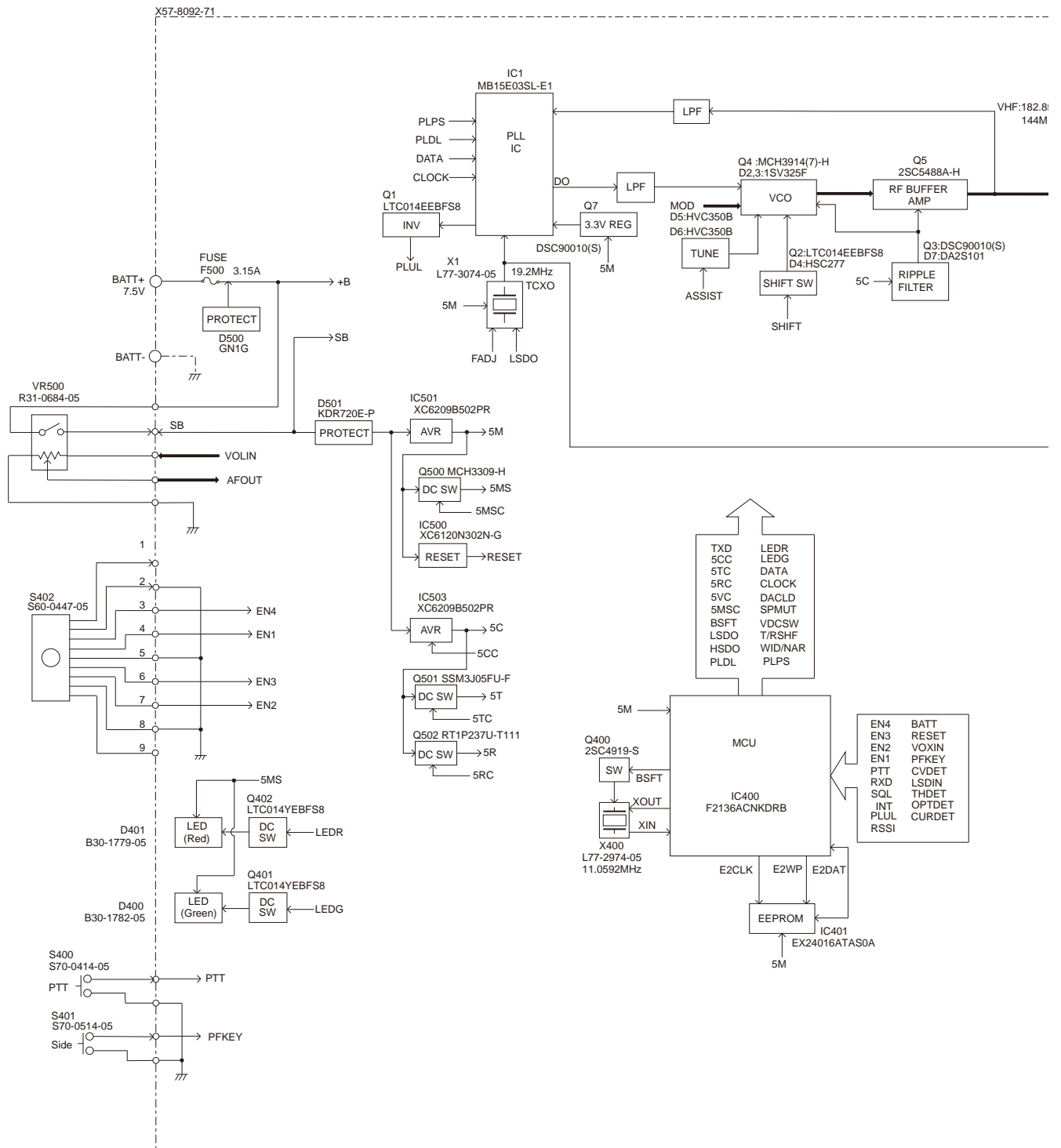

LEVEL DIAGRAM

Receiver Section

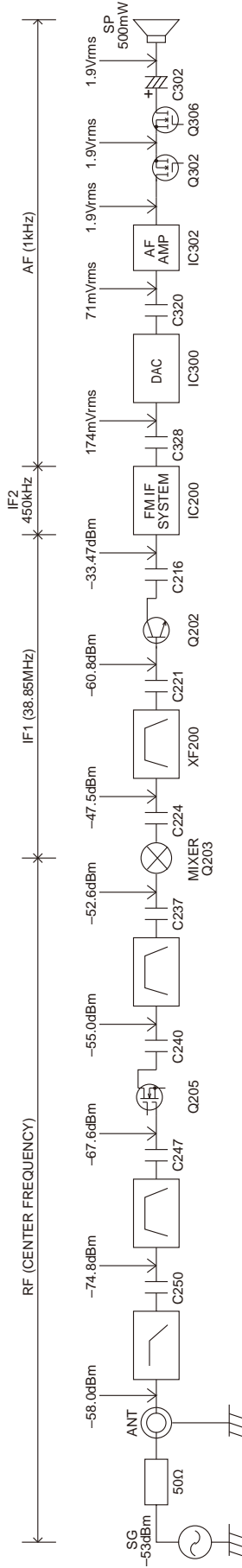

To make measurements in the AF section, connect the AC level meter.
 (ANT input: -53dBm, 1kHz FM, 1.5kHz Dev (Narrow).)
 In the RF section, use a high impedance probe. (ANT input: -53dBm, MOD off).

Transmitter Section

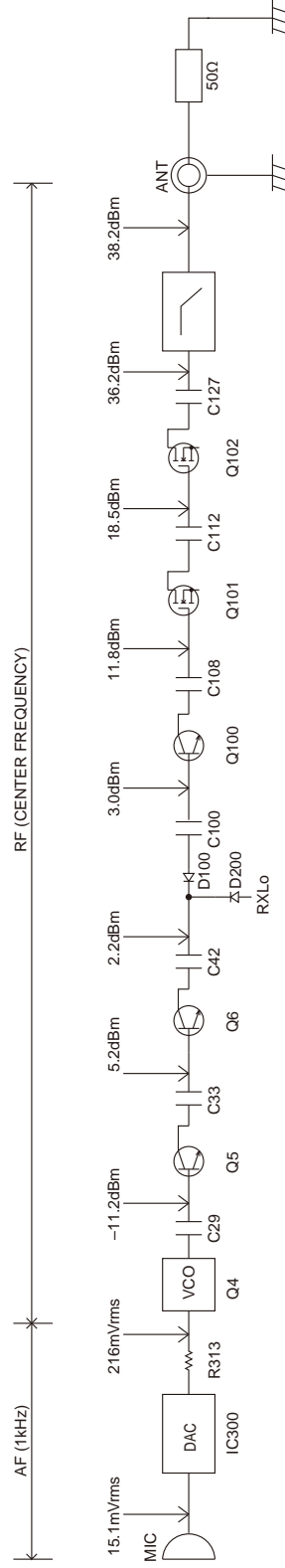

AG is set to the MIC input becomes 1.5kHz Dev, at 1kHz MOD. (Narrow)
 To make measurements in the AF section, connect the AC level meter.
 In the RF section, use a 1000pF coupling capacitor.

SPECIFICATIONS

GENERAL

Frequency Range	136~174MHz
Number of Channels	Max. 16
Channel Spacing	25kHz (Wide) / 20kHz (Wide 4k) / 12.5kHz (Narrow)
Operating Voltage	7.5 V DC±20%
Battery Life	Approx 9 hours at 5 watts (5-5-90 duty cycle) With KNB-63L battery
Operating Temperature Range	-20°C to +60°C
Frequency Stability	±5.0ppm
Channel Frequency Spread	30MHz
Dimensions and Weight (Dimensions not including protrusions)	
Radio Only	54 W x 113 H x 14 D mm, 130g
With KNB-63L battery (1130mAh battery)	54 W x 113 H x 24.9 D mm, 203g

RECEIVER (Measurements mode per EN Standards)

Sensitivity		
EIA 12dB SINAD	0.28µV (Wide/Wide 4k)	0.35µV (Narrow)
EN 20dB SINAD	-3dBµV (0.35µV) (Wide/Wide 4k)	-1dBµV (0.45µV) (Narrow)
Adjacent Channel Selectivity	70dB (Wide/Wide 4k)	60dB (Narrow)
Intermodulation.....	65dB	
Spurious Response Rejection	70dB	
Audio Distortion	Less than 5%	
Audio Output.....	500mW/8Ω	

TRANSMITTER (Measurements mode per EN Standards)

RF Output Power	5W/1W
Spurious Emission.....	-36dBm ≤ 1GHz -30dBm > 1GHz
FM Noise (EIA)	45dB (Wide) 43dB(Wide 4k) 40dB (Narrow)
Modulation Distortion.....	Less than 5%
Modulation	16K0F3E, 14K0F3E, 8K50F3E

Measurements made per EN standards or TIA/EIA 603 and specifications shown are typical.

JVC KENWOOD Corporation reserves the right to change specifications without prior notice or obligation.

TK-2000

JVC KENWOOD Corporation

3-12, Moriyacho, Kanagawa-ku, Yokohama-shi,
Kanagawa, 221-0022 Japan

Kenwood U.S.A. Corporation

P.O. BOX 22745, 2201 East Dominguez Street, Long Beach,
CA 90801-5745, U.S.A.

Kenwood Electronics Canada Inc.

6070 Kestrel Road, Mississauga, Ontario, Canada L5T 1S8

Kenwood Electronics Deutschland GmbH

Rembrücker Str. 15, 63150 Heusenstamm, Germany

Kenwood Electronics Belgium N.V.

Leuvensesteenweg 248 J, 1800 Vilvoorde, Belgium

Kenwood Electronics France S.A.

L'Etoile Paris Nord 2, 50 Allée des Impressionnistes,
Bp 58416 Villepinte, 95944 Roissy Ch De Gaulle Cedex

Kenwood Electronics UK Limited

Kenwood House, Dwight Road, Watford, Herts.,
WD18 9EB United Kingdom

Kenwood Electronics Europe B.V.

Amsterdamseweg 37, 1422 AC Uithoorn, The Netherlands

Kenwood Electronics Italia S.p.A.

Via G. Sirtori, 7/9 20129 Milano, Italy

Kenwood Ibérica, S.A.

Carretera de Rubi, 88 Planta 1 A 08174 Sant Cugat del Vallès
Barcelona, Spain

Kenwood Electronics Australia Pty. Ltd.

Talavera Business Park Building A, 4 Talavera Road,
North Ryde NSW 2113 Australia

Kenwood Electronics (Hong Kong) Ltd.

Suite 2504, 25/F, Tower 2, Nina Tower, No. 8 Yeung Uk Road,
Tsuen Wan, New Territories, Hong Kong

Kenwood Electronics Singapore Pte Ltd

1 Ang Mo Kio Street 63, Singapore 569110

TX-RX UNIT (X57-8092-71) Component side view (J79-0362-29)

TX-RX UNIT (X57-8092-71) Component side view (J79-0362-29)

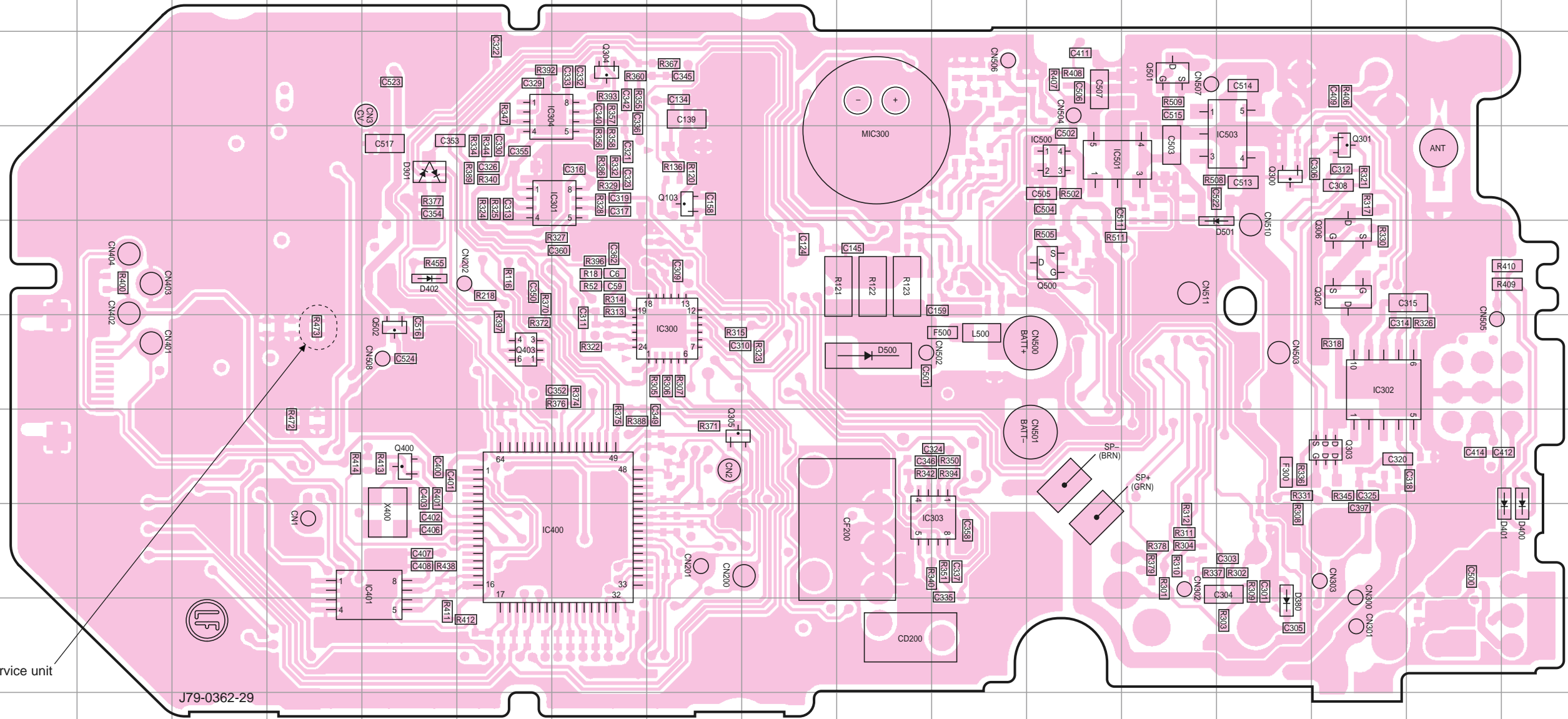

Note : for service unit

J79-0362-29

Ref. No.	Address	Ref. No.	Address	Ref. No.	Address
IC300	6I	Q103	4I	Q501	3N
IC301	4H	Q300	4O	Q500	5M
IC302	6P	Q301	4P	Q502	6F
IC303	8L	Q302	5P	D301	4F
IC304	3H	Q303	7P	D380	9O
IC400	8H	Q304	3H	D400	8R
IC401	8F	Q305	7I	D401	8R
IC500	4M	Q306	5P	D402	5F
IC501	4M	Q400	7F	D500	6K
IC503	4O	Q403	6G	D501	5O

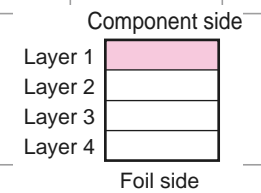

TX-RX UNIT (X57-8092-71) Foil side view (J79-0362-29)

TX-RX UNIT (X57-8092-71) Foil side view (J79-0362-29)

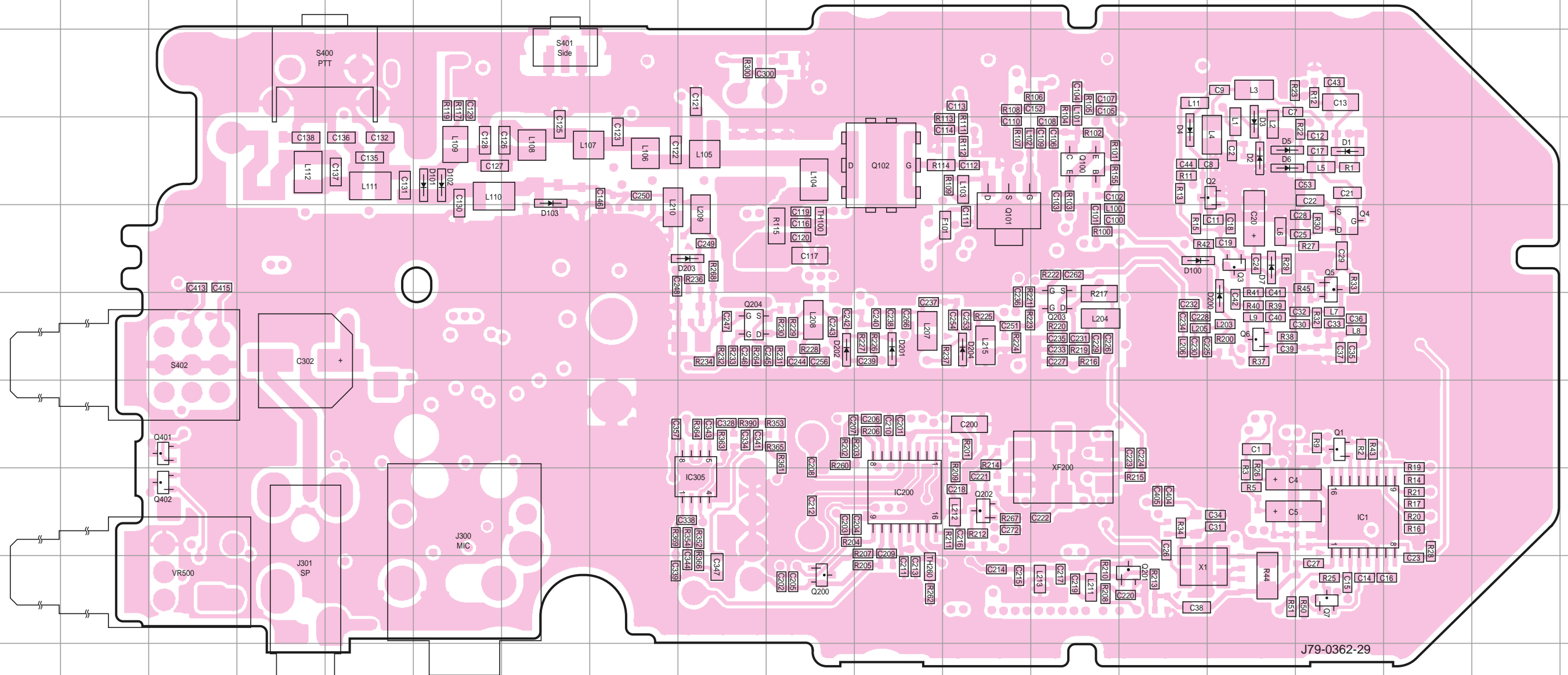

Ref. No.	Address	Ref. No.	Address	Ref. No.	Address	Ref. No.	Address
IC1	8P	Q7	9P	Q401	7C	D100	5N
IC200	8K	Q100	4M	Q402	8C	D101	4F
IC305	8I	Q101	5L	D1	4P	D102	4F
Q1	7P	Q102	4K	D2	4O	D103	5G
Q2	4O	Q200	9J	D3	4O	D200	6O
Q3	5O	Q201	9N	D4	4N	D201	6K
Q4	5P	Q202	8L	D5	4O	D202	6J
Q5	5P	Q203	6M	D6	4O	D203	5I
Q6	6O	Q204	6I	D7	5O	D204	6L

